

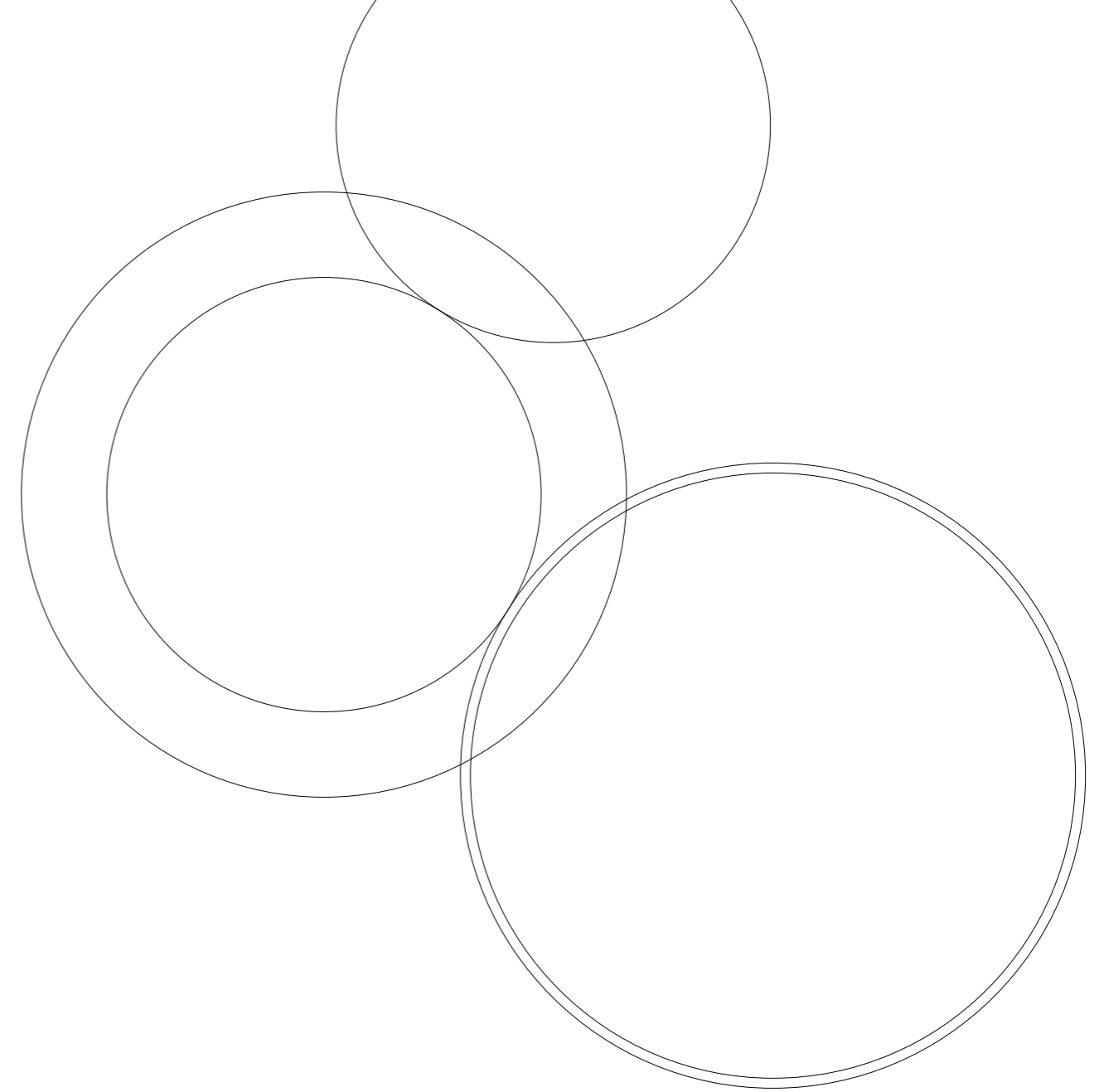

JANVIER  
**2022**

**DCW**éditions

**PARIS**



JANVIER  
**2022**

**DCW**éditions

**PARIS**

**English** • There are objects born  
from desire and objects born from love.  
There are objects that disappear,  
scattered by the winds of time.  
To be of one's time is to share the destiny  
of the dead leaves.  
Only truth and beauty are eternal.

**Italiano** • Vi sono oggetti che nascono  
dal desiderio e dall'amore.  
Vi sono oggetti che spariscono,  
portati via dal tempo.  
Essere in sintonia con i tempi,  
significa avere il destino delle foglie morte.  
Solo il bello ed il giusto sono eterni.

**Deutsch** • Es gibt Objekte, geboren aus  
Wünschen und Objekte, geboren aus Liebe.  
Es gibt Objekte, die verschwinden,  
zerstreut von den Winden der Zeit.  
Um einmal das Schicksal der toten Blätter zu teilen.  
Nur die Wahrheit und Schönheit sind ewig.

**Español** • Hay objetos que nacen  
del deseo y el amor.  
Hay objetos que desaparecen,  
llevados por el aire.  
Estar en sintonia con los tiempos,  
es tener el destino de las hojas muertas.  
Solo la verdad y la belleza son eternas.

Il y a des objets qui naissent  
du désir et de l'amour.  
Il y a des objets qui disparaissent,  
soufflés par l'air du temps.

Être dans l'air du temps,  
c'est avoir le destin  
des feuilles mortes. **Jean Guilton**

Seuls le beau et le juste  
sont éternels.

**DCW**éditions

PARIS

**FOCUS**  
de Yuji Okitsu

NEW

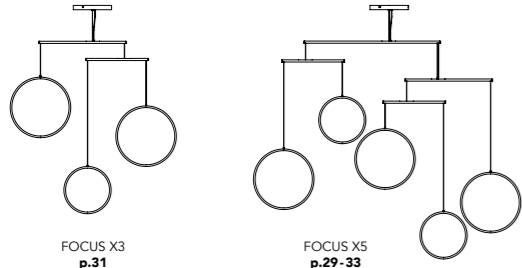

FOCUS X3  
p.31

FOCUS X5  
p.29-33

**MONO**  
de Vantot

NEW

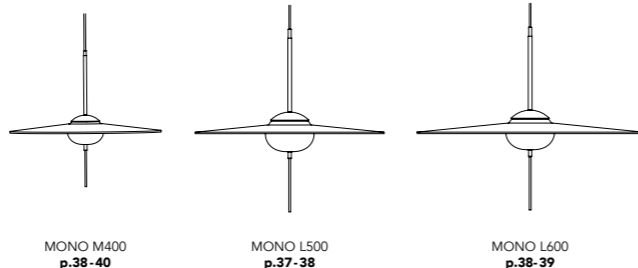

MONO M400  
p.38-40

MONO L500  
p.37-38

MONO L600  
p.38-39

**ARMEN**  
de Grégoire de Lafforest

NEW

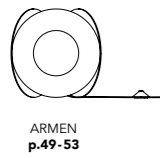

ARMEN  
p.49-53

**YASUKE**  
de Studio BricchetZiegler

NEW

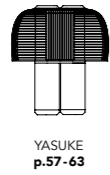

YASUKE  
p.57-63

**LA LAMPE FRECHIN**  
de Jean-Louis Frechin

NEW



LA LAMPE FRECHIN  
p.67-71

**PAN**  
de Simon Schmitz

NEW



PAN  
p.76-77

**MIDNIGHT**  
de Stéphanie Cayet

NEW

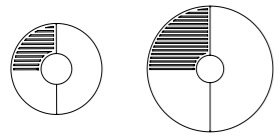

MIDNIGHT 325  
p.80

MIDNIGHT 505  
p.78-81

**DELUMINA**  
de Giulia Liverani

NEW

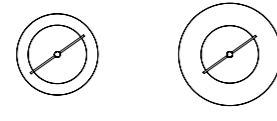

DELUMINA WALL 250  
p.82

DELUMINA WALL 320  
p.82-83

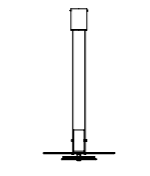

DELUMINA PENDANT  
p.44-45

**BORELY**  
d'Éric Gizard

NEW



BORELY  
p.84-85

**ROSALIE**  
de Julie Fuillet

NEW



ROSALIE  
p.86-87

**TOBO**  
de DCWéditions

NEW

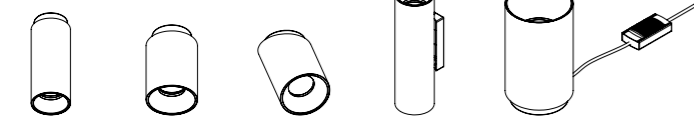

TOBO C65  
p.103-104

TOBO C85  
p.103-104

TOBO C85 DIAG  
p.104-105

TOBO W65  
p.103-104

TOBO FLOOR  
p.104-105

**VISION 20/20**  
de DCWéditions

NEW

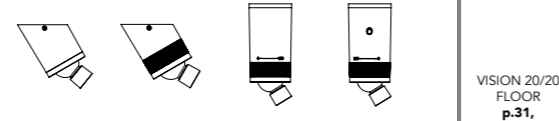

VISION 20/20  
p.114

VISION 20/20 SW  
p.114

VISION 20/20 OMNI  
p.112, 115

VISION 20/20 OMNI SW  
p.115

VISION 20/20 FLOOR  
p.31, 109-111, 113

**ORG**  
de Sebastian Summa

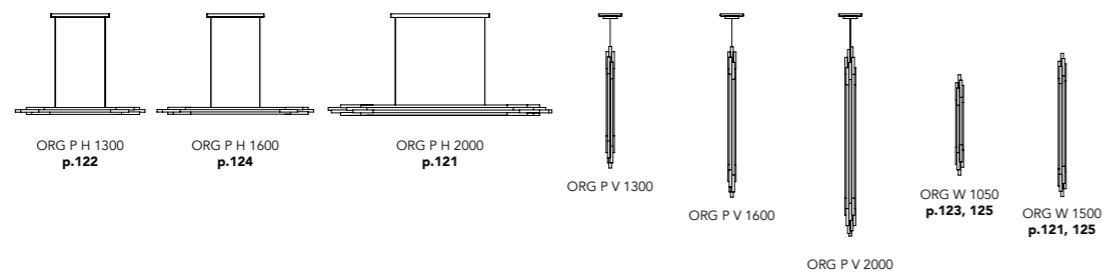

ORG P H 1300  
p.122

ORG P H 1600  
p.124

ORG P H 2000  
p.121

ORG P V 1300

ORG P V 1600

ORG W 1050  
p.123, 125

ORG W 1500  
p.121, 125

ORG P V 2000

**AARO**  
de Simon Schmitz

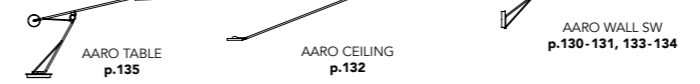

AARO TABLE  
p.135

AARO CEILING  
p.132

AARO WALL SW  
p.130-131, 133-134

**COLLECTION CORDLESS**

ITS TABLE  
p.94-96, 151, 157, 160

KNOKKE  
p.95-96, 151, 153, 157, 159

BOUCLE  
p.94, 97, 151, 153, 156, 158, 161

**RESPIRO**  
de Philippe Nigro

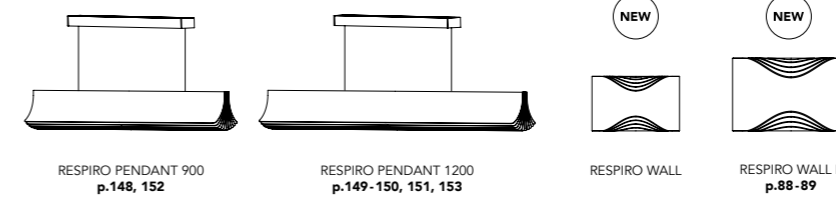

RESPIRO PENDANT 900  
p.148, 152

RESPIRO PENDANT 1200  
p.149-150, 151, 153

RESPIRO WALL

RESPIRO WALL L  
p.88-89

**VVV**  
de Vantot

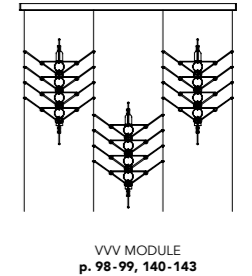

VVV MODULE  
p.98-99, 140-143

**BINY**  
de Jacques Biny

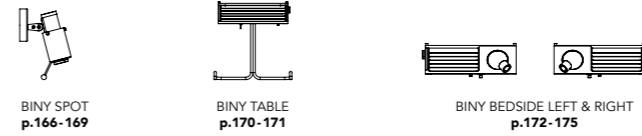

BINY SPOT  
p.166-169

BINY TABLE  
p.170-171

BINY BEDSIDE LEFT & RIGHT  
p.172-175

**IN THE SUN**  
de Dominique Perrault & Gaëlle Lauriot-Prévo

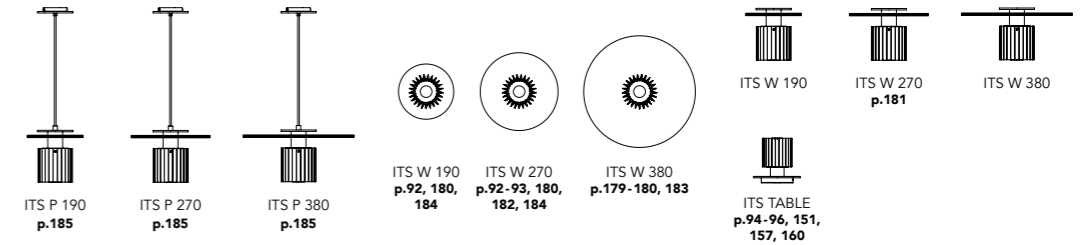

ITS P 190  
p.185

ITS P 270  
p.185

ITS P 380  
p.185

ITS W 190  
p.92, 180, 184

ITS W 270  
p.92-93, 180, 182, 184

ITS W 380  
p.179-180, 183

ITS W 190

ITS W 270  
p.181

ITS W 380

ITS TABLE  
p.94-96, 151, 157, 160

**IN THE TUBE**  
de Dominique Perrault & Gaëlle Lauriot-Prévo

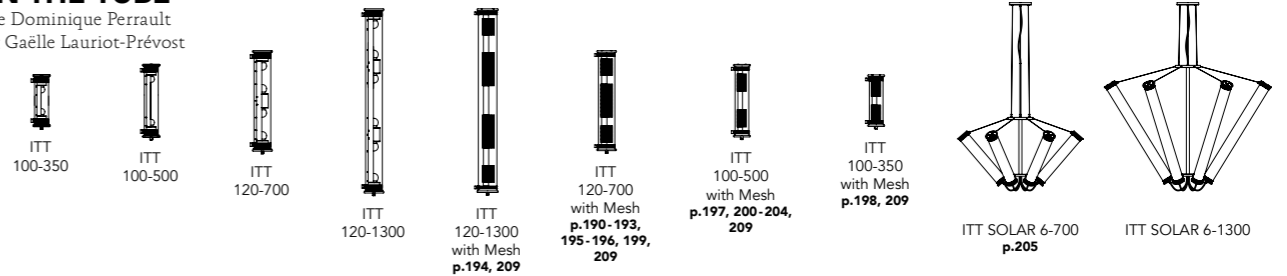

ITT 100-350

ITT 100-500

ITT 120-700

ITT 120-1300

ITT 120-1300 with Mesh  
p.194, 209

ITT 120-700 with Mesh  
p.190-193, 195-196, 199, 209

ITT 100-500 with Mesh  
p.197, 200-204, 209

ITT 100-350 with Mesh  
p.198, 209

ITT SOLAR 6-700  
p.205

ITT SOLAR 6-1300

**IN THE TUBE 360°**  
de Dominique Perrault & Gaëlle Lauriot-Prévo

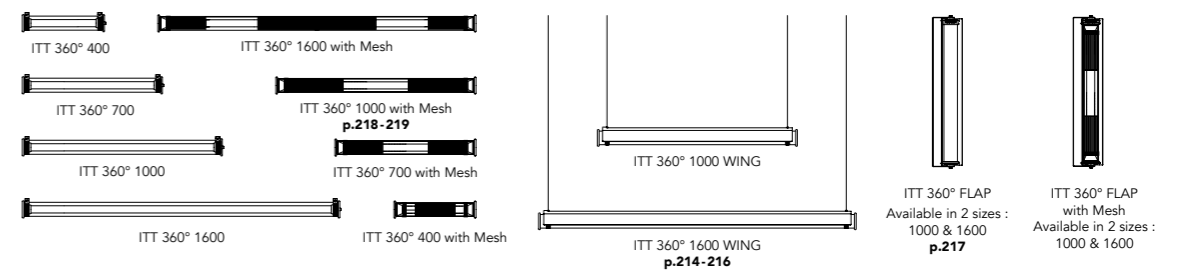

ITT 360° 400

ITT 360° 1600 with Mesh

ITT 360° 700

ITT 360° 1000 with Mesh  
p.218-219

ITT 360° 1000

ITT 360° 700 with Mesh

ITT 360° 1600

ITT 360° 400 with Mesh

ITT 360° 1000 WING

ITT 360° 1600 WING  
p.214-216

ITT 360° FLAP

Available in 2 sizes : 1000 & 1600  
p.217

ITT 360° FLAP with Mesh

Available in 2 sizes : 1000 & 1600



**COLLECTION**  
d'Éric de Dormael

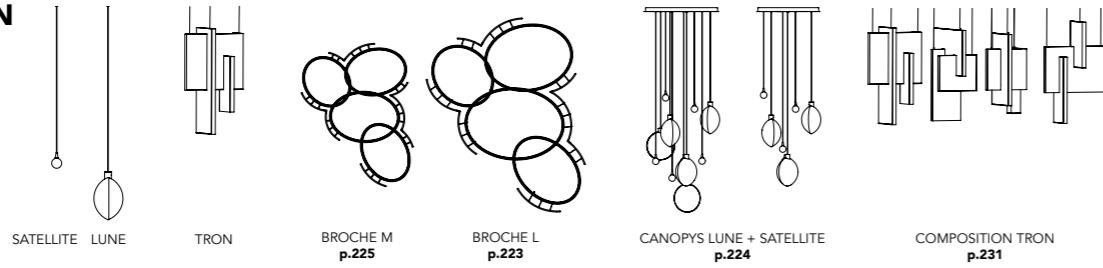

SATELLITE LUNE TRON BROCHE M p.225 BROCHE L p.223 CANOPYS LUNE + SATELLITE p.224 COMPOSITION TRON p.231

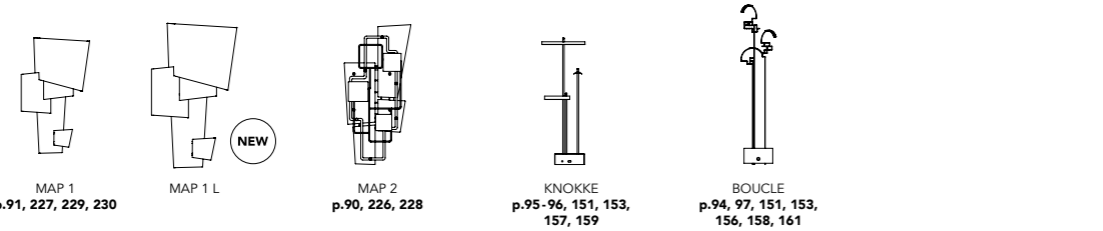

MAP 1 p.91, 227, 229, 230 MAP 1 L (NEW) MAP 2 p.90, 226, 228 KNOCKE p.95-96, 151, 153, 157, 159 BOUCLE p.94, 97, 151, 153, 156, 158, 161

**ISP**  
de Ilia Sergeevich Potemine

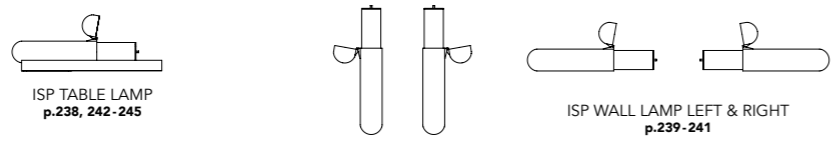

ISP TABLE LAMP p.238, 242-245 ISP WALL LAMP LEFT & RIGHT p.239-241

**MANTIS**  
de Bernard Schottlander

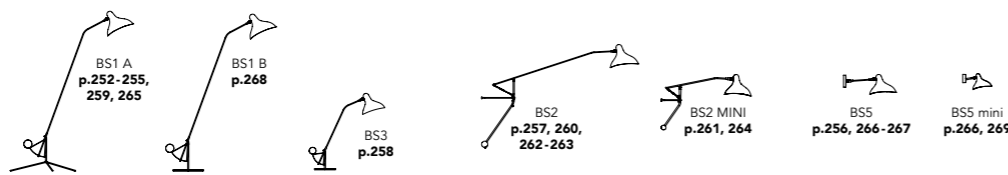

BS1 A p.252-255, 259, 265 BS1 B p.268 BS2 p.257, 260, 262-263 BS2 MINI p.261, 264 BS3 p.258 BS5 p.256, 266-267 BS5 mini p.266, 269

**HERE COMES THE SUN**  
de Bertrand Balas

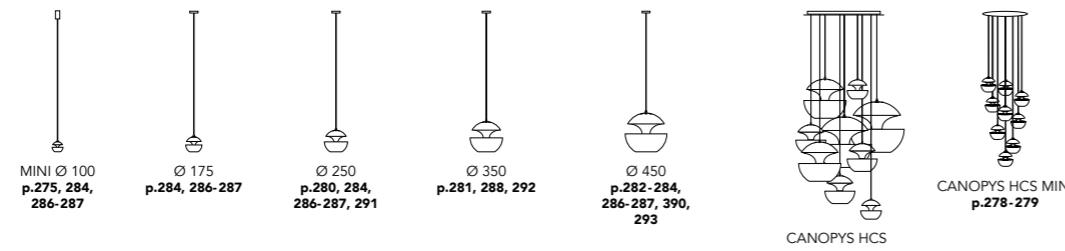

MINI Ø 100 p.275, 284, 286-287 Ø 175 p.284, 286-287 Ø 250 p.280, 284, 286-287, 291 Ø 350 p.281, 288, 292 Ø 450 p.282-284, 286-287, 390, 293 CANOPYS HCS CANOPYS HCS MINI p.278-279

**LES ACROBATES DE GRAS**

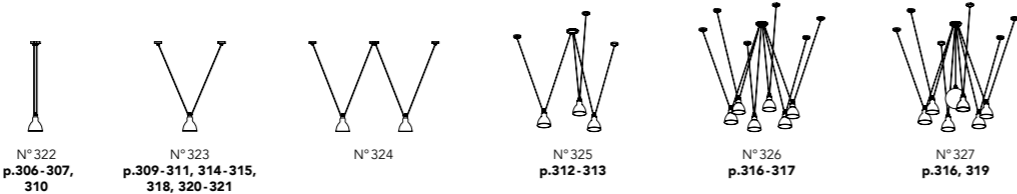

N° 322 p.306-307, 310 N° 323 p.309-311, 314-315, 318, 320-321 N° 324 N° 325 p.312-313 N° 326 p.316-317 N° 327 p.316, 319

**LAMPE GRAS** de Bernard-Albin Gras

**TABLE LAMPS**



N° 205 p.330-333 N° 207 p.334-335 N° 317 p.336-337

**ARCHITECT AND BOOKSHELF LAMPS**



N° 201 p.338-339 N° 226 p.340-341

**FLOOR LAMPS**

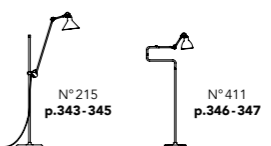

N° 215 p.343-345 N° 411 p.346-347

**CEILING LAMPS**

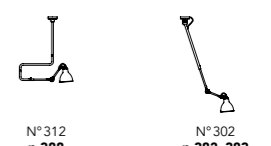

N° 312 p.388 N° 302 p.382-383

**WALL LAMPS**

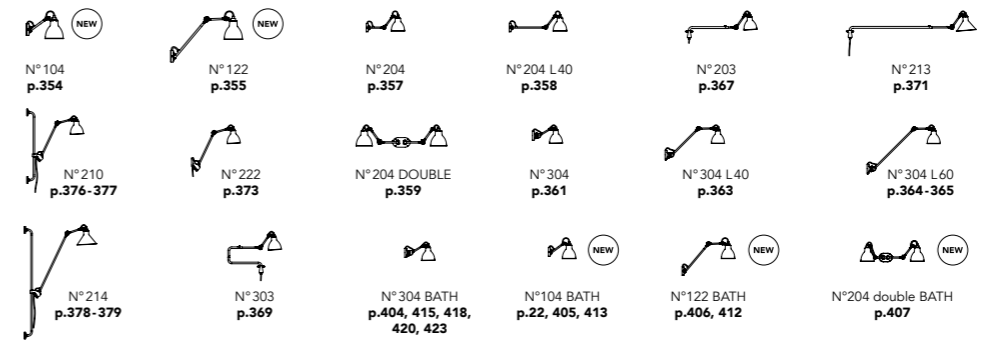

N° 104 p.354 (NEW) N° 122 p.355 (NEW) N° 204 p.357 N° 204 L40 p.358 N° 203 p.367 N° 213 p.371 N° 210 p.376-377 N° 222 p.373 N° 204 DOUBLE p.359 N° 304 p.361 N° 304 L40 p.363 N° 304 L60 p.364-365 N° 214 p.378-379 N° 303 p.369 N° 304 BATH p.404, 415, 418, 420, 423 N° 104 BATH p.22, 405, 413 (NEW) N° 122 BATH p.406, 412 (NEW) N° 204 double BATH p.407 (NEW)

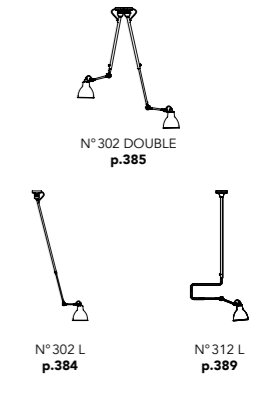

N° 302 DOUBLE p.385 N° 302 L p.384 N° 312 L p.389

**COLLECTION OUTDOOR**

**LAMPE GRAS OUTDOOR SEASIDE**



N° 304 XL OUTDOOR SEASIDE p.394-395

**IN THE TUBE**  
de Dominique Perrault & Gaëlle Lauriot-Prévoist  
(without or with Mesh)

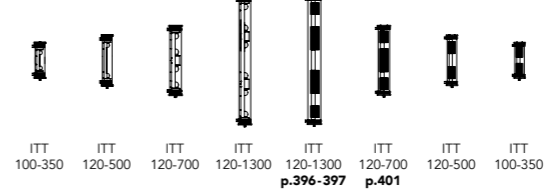

ITT 100-350 ITT 120-500 ITT 120-700 ITT 120-1300 ITT 120-1300 ITT 120-700 ITT 120-500 ITT 100-350 p.396-397 p.401

**IN THE TUBE 360°**  
de Dominique Perrault & Gaëlle Lauriot-Prévoist

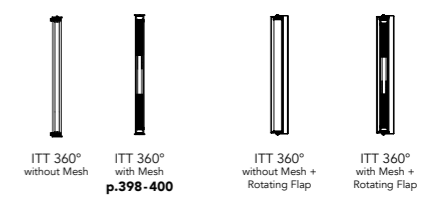

ITT 360° without Mesh ITT 360° with Mesh p.398-400 ITT 360° without Mesh + Rotating Flap ITT 360° with Mesh + Rotating Flap

**COLLECTION BATHROOM**

**LAMPE GRAS**  
de Bernard-Albin Gras

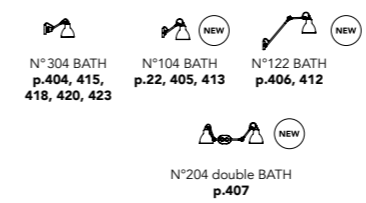

N° 304 BATH p.404, 415, 418, 420, 423 (NEW) N° 104 BATH p.22, 405, 413 (NEW) N° 122 BATH p.406, 412 (NEW) N° 204 double BATH p.407

**MIROIR My best Enemy Tell Me Stories**

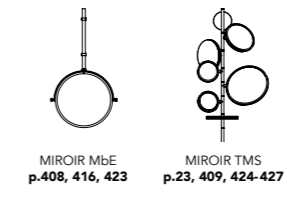

MIROIR MbE p.408, 416, 423 MIROIR TMS p.23, 409, 424-427

**ITT & ITT 360°**  
de Dominique Perrault & Gaëlle Lauriot-Prévoist

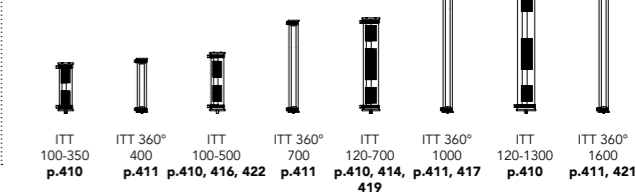

ITT 100-350 p.410 ITT 360° 400 p.411 ITT 100-500 p.410, 416, 422 ITT 360° 700 p.411 ITT 120-700 p.410, 414, p.411, 417 1000 p.411 ITT 120-1300 1600 p.410 ITT 360° 1600 p.411, 421

**MIROIR My best Enemy MbE**  
de DCWéditions



MIROIRS MbE p.408, 416, 423

**MIROIR Tell Me Stories TMS**  
de Giulia Liverani

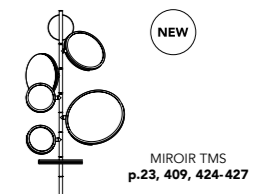

MIROIR TMS p.23, 409, 424-427 (NEW)

# EDI- TO

**English** • For those who love to touch the light  
For those who love to take their time  
For those who love to think, to dream  
For those who love objects  
For those who love their home, with family, with friends.  
For those not afraid to be themselves  
For those who don't like the light from the refrigerator.  
Welcome home.

**Deutsch** • Für jene, die dem Licht nahe sein möchten,  
Für alle, die sich gerne Zeit lassen,  
Für alldiejenigen, die gerne nachdenken und träumen,  
Für alle Liebhaber schöner Objekte,  
Für jene, die ihr Haus mit Familie und Freunden teilen  
Für alle Mutigen, die keine Angst haben, sie selbst zu sein,  
Und für solche, die das Licht des Kühlschranks nicht mögen,  
Willkommen Zuhause.

Pour ceux...

qui aiment toucher la lumière,

Pour ceux qui aiment prendre leur temps,  
Pour ceux qui aiment penser, rêver,  
Pour ceux qui aiment les objets,  
Pour ceux qui aiment leur maison, en famille, entre amis.

Pour ceux qui n'ont pas peur d'être eux-mêmes,  
Pour ceux qui n'aiment pas la lumière du réfrigérateur.

Bienvenue à la maison.

**Español** • Para aquellos que les gusta acariciar la luz,  
Para aquellos que les gusta tomarse su tiempo,  
Para aquellos que les gusta pensar, soñar,  
Para aquellos que les gustan los objetos,  
Para aquellos que aman su hogar en familia, entre amigos.  
Para aquellos que no tienen miedo de ser ellos mismos,  
Para aquellos a los que no les gusta la luz del frigorífico.  
Bienvenidos a casa.

**Italiano** • Per quelli che la luce la toccano,  
Per quelli che sono ... slow,  
Per quelli che ancora pensano e sognano,  
Per quelli che amano gli oggetti,  
Per quelli che, con la famiglia e con gli amici, amano la loro casa.  
Per quelli che non temono di essere se stessi,  
Per quelli che detestano la luce del frigorifero, a tutti quanti loro.  
Benvenuti a casa.

# WHAT'S NEW ?

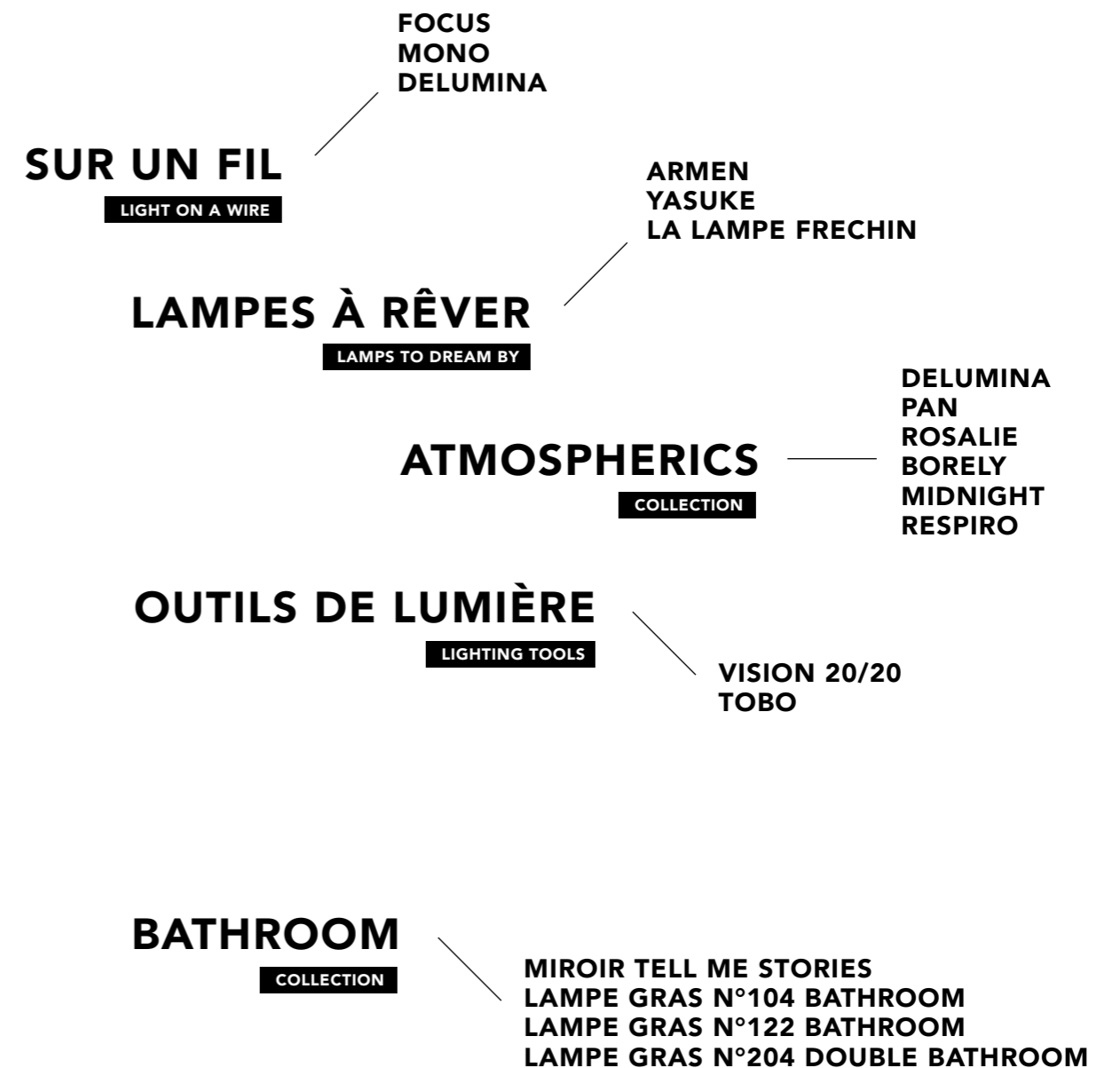

## FOCUS

Planètes ou bulles de savon ?  
De Yuji Okitsu  
P. 27



## DELUMINA PENDANT

De Giulia Liverani  
P. 43

## NEW SUR UN FIL LIGHT ON A WIRE

## MONO

Grâce au « Magicstick »  
le voyageur de l'espace joue  
avec l'intensité lumineuse.

De Vantot  
P. 35







## ARMEN

Inspirée des formes géométriques et des objets mathématiques, Armen est un jeu d'imbrication et d'équilibre.

De Grégoire de Lafforest  
P. 47



## YASUKE

Entre architecture futuriste, crinoline de lumière du XXI<sup>ème</sup> siècle, ou vaisseau spatial...

De BrichetZiegler  
P. 55

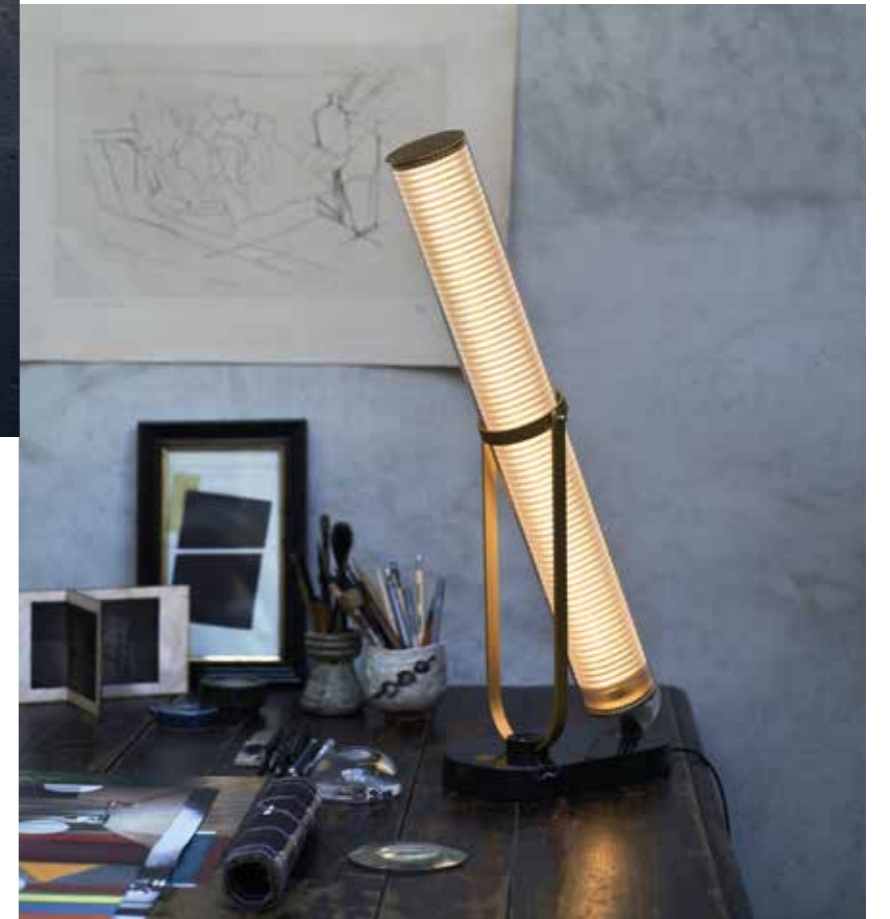

## LA LAMPE FRECHIN

Entre science et magie, la Lampe Frechin propose une expérience sensible de l'optique.

De Jean-Louis Frechin  
P. 65

# NEW LAMPES À RÊVER

LAMPS TO DREAM BY



**BORELY**  
D'Éric Gizard  
P. 84

**MIDNIGHT**  
De Stéphanie Cayet  
P. 78



La lumière des Atmospherics  
nous invite à voir sans voir  
et laisse place au calme

**NEW**  
**ATMOSPHERICS**  
COLLECTION

**DELUMINA**  
De Giulia Liverani  
P. 82



**PAN**  
De Simon Schmitz  
P. 76





**NEW**  
**ATMOSPHERICS**  
COLLECTION  
**GOLD**



**BORELY**  
D'Éric Gizard  
P. 84



**ROSALIE**  
De Julie Fullet  
P. 86



**RESPIRO**  
De Philippe Nigro  
P. 88

# NEW

## OUTILS DE LUMIÈRE

LIGHTING TOOLS



### TOBO

Tobo est une gamme de compléments qui propose à la fois un éclairage technique et une ambiance chaleureuse, presque théâtrale.  
De DCWéditions  
**P. 101**



### VISION 20/20

L'outil de lecture indispensable, car la vue ne tolère pas la médiocrité.

De DCWéditions  
**P. 107**





**NEW**  
**BATHROOM**  
COLLECTION

**TELL ME STORIES**

De Giulia Liverani  
P. 409



**LAMPE GRAS**  
**N°104 BATHROOM**

De DCWéditions  
P. 405



**ROOTS  
IN THE  
PAST  
THOUGHT  
TODAY  
TO BE  
SHIPPED  
IN THE  
FUTURE**

The way we behave

**DCW**éditions

PARIS

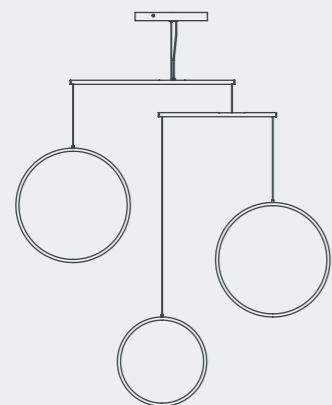

FOCUS x3

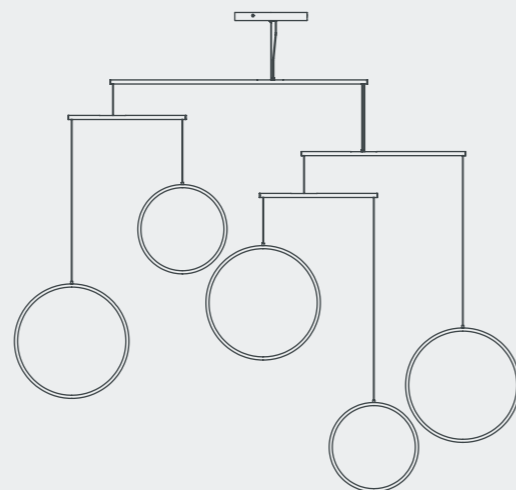

FOCUS x5

# FOCUS<sup>TM</sup>

de Yuji Okitsu

**NEW**  
**SUR UN FIL**  
LIGHT ON WIRE

# FOCUS™

de Yuji Okitsu



Yuji Okitsu

Les planètes ne sont-elles pas des bulles de savon qui n'auraient jamais éclaté dans leur voyage. À force de les observer avec sa lunette d'astronomie, Yuji les a apprivoisées, pour les faire flotter dans une atmosphère légère.

**English** • But what if the planets were nothing more than soap bubbles that have remained intact as they travel through time? Armed with his astronomer's telescope that let him observe their every movement, Yuji has transformed them into objects floating in a weightless world.

**Deutsch** • Aber was wäre, wenn die Planeten nichts anderes als Seifenblasen wären, die auf ihrer Reise durch die Zeit intakt geblieben sind? Ausgerüstet mit dem Teleskop eines Astronomen, mit dem er jede ihrer Bewegungen beobachten kann, hat Yuji sie in Objekte verwandelt, die sich in einer schwerelosen Welt bewegen.

**Italiano** • E se i pianeti non fossero altro che delle bolle di sapone, mai scoppiate durante il loro viaggio? A forza di osservarli con il suo telescopio, Yuji li ha domati, per farli galleggiare in un'atmosfera leggera.

**Español** • ¿No son las burbujas de jabón planetas que nunca estallaron en su viaje? A fuerza de observarlos con su telescopio astronómico, Yuji los domó, para hacerlos flotar en una atmósfera ligera.

Right page: FOCUS x5 WH







Left page: FOCUS x5 WH  
Right page: FOCUS x5 BL+ FOCUS x3 BL + VISION 20/20 FLOOR  
Pages 32 - 33: FOCUS x5 BL







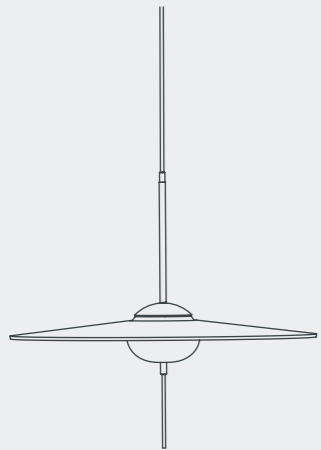

MONO M400  
Glass planet Ø94 mm  
Tilting glass ring Ø400 mm

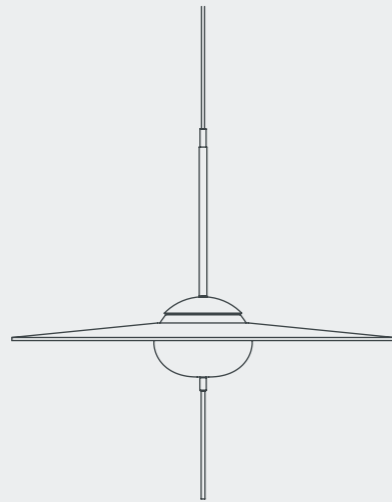

MONO L500  
Glass planet Ø128 mm  
Tilting glass ring Ø500 mm

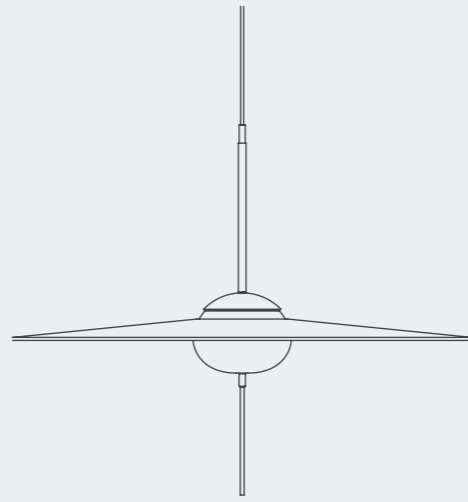

MONO L600  
Glass planet Ø128 mm  
Tilting glass ring Ø600 mm

**MONO**<sup>TM</sup>

de Vantot

**NEW**  
**SUR UN FIL**  
LIGHT ON WIRE

# MONO<sup>TM</sup>

de Vantot



Vantot

## **Mono et son « Magicstick »**

Trouvés suspendus à une liane, Mono et son « Magicstick » tombés du ciel, fonctionnent encore ! Pour faire rire la lune, le voyageur de l'espace joue avec l'intensité lumineuse de Mono. Le magicstick est un ON/OFF variateur d'intensité. Mono créé par le studio « Vantot », inventeur de VVV. (Esther et Sam si souriants et délicats sont des anges tombés en Hollande).

**English • Mono and his « Magicstick ».** Found clinging to a creeper, Mono and his 'Magicstick' tumbled to earth, but still manages to work! To give the moon a laugh, the space traveller can vary the intensity of the light Mono gives off. The Magicstick is an On/Off dimmer switch. Mono emanates from the 'Vantot' design studio, inventor of VVV. (Esther and Sam, always smiling, always graceful to a T, are two angels who have fallen to earth, landing as if by chance in Holland).

## **Deutsch • Mono und sein « Magicstick »**

Mono und sein "Magicstick" haben sich an einer Kletterpflanze festgehalten und sind auf die Erde gestürzt, funktionieren aber immer noch! Um den Mond zum Lachen zu bringen, kann der Raumfahrer die Intensität des Lichts, das Mono abgibt, variieren. Der Magicstick ist ein Ein/Aus-Dimmerschalter. Mono stammt aus dem Designstudio 'Vantot', dem Erfinder von VVV. (Esther und Sam, immer lächelnd, immer anmutig, sind zwei Engel, die auf die Erde gefallen sind und wie zufällig in Holland gelandet sind).

## **Italiano • Mono e il suo « Magicstick »**

Trovati appesi ad un rampicante, Mono e il suo « Magicstick » sono caduti dal cielo e funzionano ancora! Per far ridere la luna, l'astronauta gioca con l'intensità della luce di Mono. Il magicstick è un dimmer ON/OFF. Mono è stato creato dallo studio «Vantot», inventore di VVV. (Esther e Sam così sorridenti e delicati sono angeli caduti in Olanda).

## **Espanöl • Mono y su « Magicstick »**

Encontrado colgando de una liana, Mono y su « Magicstick » caídos del cielo, ¡todavía funcionan! Para hacer reír a la luna, el viajero espacial juega con la intensidad de la luz de Mono. La varilla mágica es un atenuador de encendido y apagado. Mono, creado por el estudio «Vantot», inventores de VVV. (Esther y Sam tan sonrientes y delicados son ángeles caídos en Holanda).

Right page: MONO L500







COLLECTION | **MONO**



*Left page*  
MONO L500  
+ MONO M400  
+ MONO L600

*Right page*  
MONO L600





*Left page*  
MONO M400

*Right page*  
2 x MONO L600



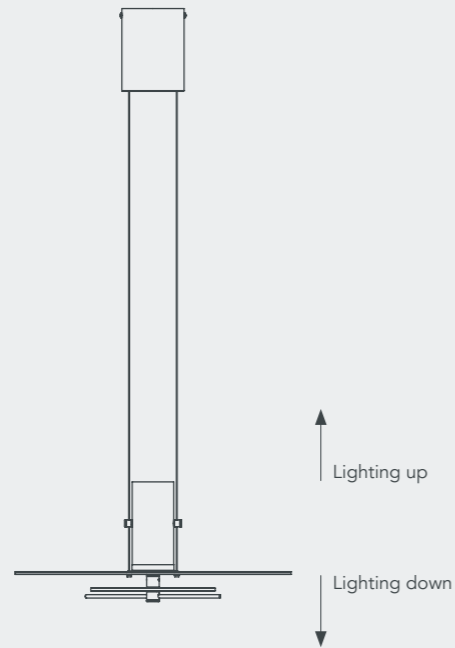

DELUMINA PENDANT  
Glassing ring Ø400 mm

# DELUMINA<sup>TM</sup>

de Giulia Liverani

**NEW**  
**SUR UN FIL**  
LIGHT ON WIRE





*Left and right pages : DELUMINA PENDANT*

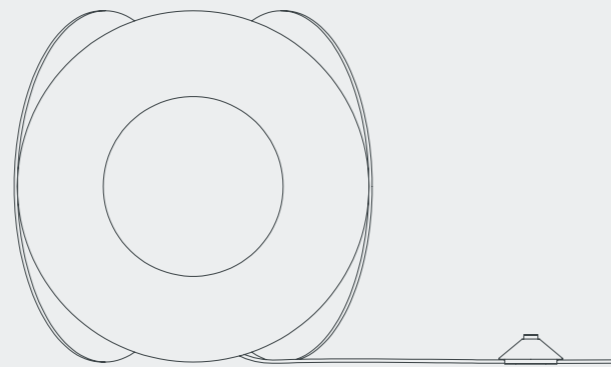

ARMEN

Glass ball Ø191 mm  
Metal ring Ø312 mm

# ARMEN™

de Grégoire de Lafforest

**NEW**  
**LAMPES À RÊVER**  
LAMPS TO DREAM BY



# ARMEN™

de Grégoire de Lafforest

Grégoire de Lafforest



Inspirée des formes géométriques et des objets mathématiques, Armen est un jeu d'imbrication et d'équilibre entre deux formes simples : le cône et la sphère. À l'image du phare éponyme, la lumière est guidée par les trois cônes.

**English** • Inspired by geometric shapes and mathematical objects, Armen is a game of imbrication and balance between two simple forms: the cone and the sphere. Like the eponymous lighthouse, the light is guided by the three cones.

**Deutsch** • Inspiriert von geometrischen Formen und mathematischen Objekten, Armen ist ein Spiel aus Verflechtung und Gleichgewicht zwischen zwei einfachen Formen: dem Kegel und der Kugel. Wie der gleichnamige Leuchtturm wird das Licht von den drei Kegeln gelenkt.

**Italiano** • Ispirato da forme geometriche e oggetti matematici, Armen è un gioco di intrecci e di equilibri tra due forme semplici: il cono e la sfera. Come l'omonimo faro, la luce è guidata dai tre coni. Calda o fredda, debole o intensa, la luce può essere regolata secondo i vostri desideri.

**Español** • Armen es un juego de entrelazamiento y equilibrio entre dos formas simples: el cono y la esfera. Como el faro del mismo nombre, la luz es guiada por los tres conos. Caliente o fría, débil o intensa, la luz se puede ajustar a nuestro gusto.

Right page: ARMEN







ARMEN



ARMEN





Left and  
right pages:  
ARMEN





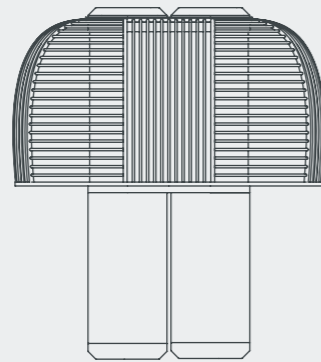

YASUKE

# YASUKE™

de BrichetZiegler

**NEW**  
**LAMPES À RÊVER**  
LAMPS TO DREAM BY

# YASUKE™

de BrichetZiegler

Caroline Ziegler & Pierre Brichet



**1550-1590** Du soleil couchant au soleil levant, d'esclave à Samouraï, Yasuke traverse les océans et les continents.  
**2021-2022-2023...** Le luminaire Yasuke vous invite au voyage de la lumière douce et chaude, à la lumière vive du soleil de midi. Entre architecture futuriste, crinoline de lumière du XXIème siècle, vaisseau spatial... Chacun crée son monde de lumière à l'aide de **deux variateurs (température de couleur et intensité de lumière)**.

Imaginée et dessinée par le Studio BrichetZiegler.

**English • 1550-1590** From the rising of the sun to its setting in the evening, from slave to Samurai, Yasuke traverses oceans, crosses continents.

**2021-2022-2023...** The Yasuke lamp brings you on a voyage from soft, warm tones to the bright light of the southern sun. Somewhere between a piece of futurist architecture, a form of 21st century crinoline and a spaceship... Everyone can make their own lighting environment using two dimmers: **one to control the bulb's colour temperature, the other its brightness.** Conceived and designed by BrichetZiegler.

**Deutsch • 1550-1590** Vom Sonnenaufgang bis zum Untergang am Abend, vom Sklaven bis zum Samurai, durchquert Yasuke Ozeane und Kontinente.

**2021-2022-2023...** Die Yasuke Leuchte nimmt sie mit auf eine Reise aus sanften, warmen Tönen zum hellen Licht der südlichen Sonne.

Irgendwo zwischen einem Stück futuristischer Architektur, eine Form des Reifrocks des 21. Jahrhunderts und eines Raumschiffs...

Jeder kann mit zwei Dimmern seine Lichtumgebung gestalten: **Einer, um die Farbtemperatur der Lichtquelle zu steuern, der andere, um die Helligkeit zu regeln.**

Konzipiert und gestaltet von BrichetZiegler.

**Deutsch • 1550-1590** Dal sorgere del sole al suo tramonto, la sera. Da schiavo a Samurai, Yasuke attraversa gli oceani e i continenti.

**2021-2022-2023...** La lampada Yasuke ti accompagna in un viaggio dai toni soffusi, caldi alla luce intensa del sole del sud.

Qualche parte tra un elemento di architettura futuristica, una crinolina del 21esimo secolo e una navicella spaziale... Ognuno può creare il proprio ambiente luminoso usando due dimmer:

**Uno per controllare la temperatura di colore della lampadina, l'altro la sua luminosità.**

Ideata e progettata da BrichetZiegler.

**Español • 1550-1590** Desde el levante hasta el poniente, de esclavo a samurái, Yasuke cruza océanos, cruza continentes.

**2021-2022-2023 ...** La lámpara Yasuke nos invita a un viaje desde la luz suave y cálida, hasta la luz viva del sol del mediodía. Entre arquitectura futurista, crinolina de luz del siglo XXI, astronave...

**Todo el mundo crea su propio mundo de luz utilizando dos atenuadores (temperatura de color e intensidad luminosa).** Imaginado y diseñado por Studio BrichetZiegler.

Right page: YASUKE





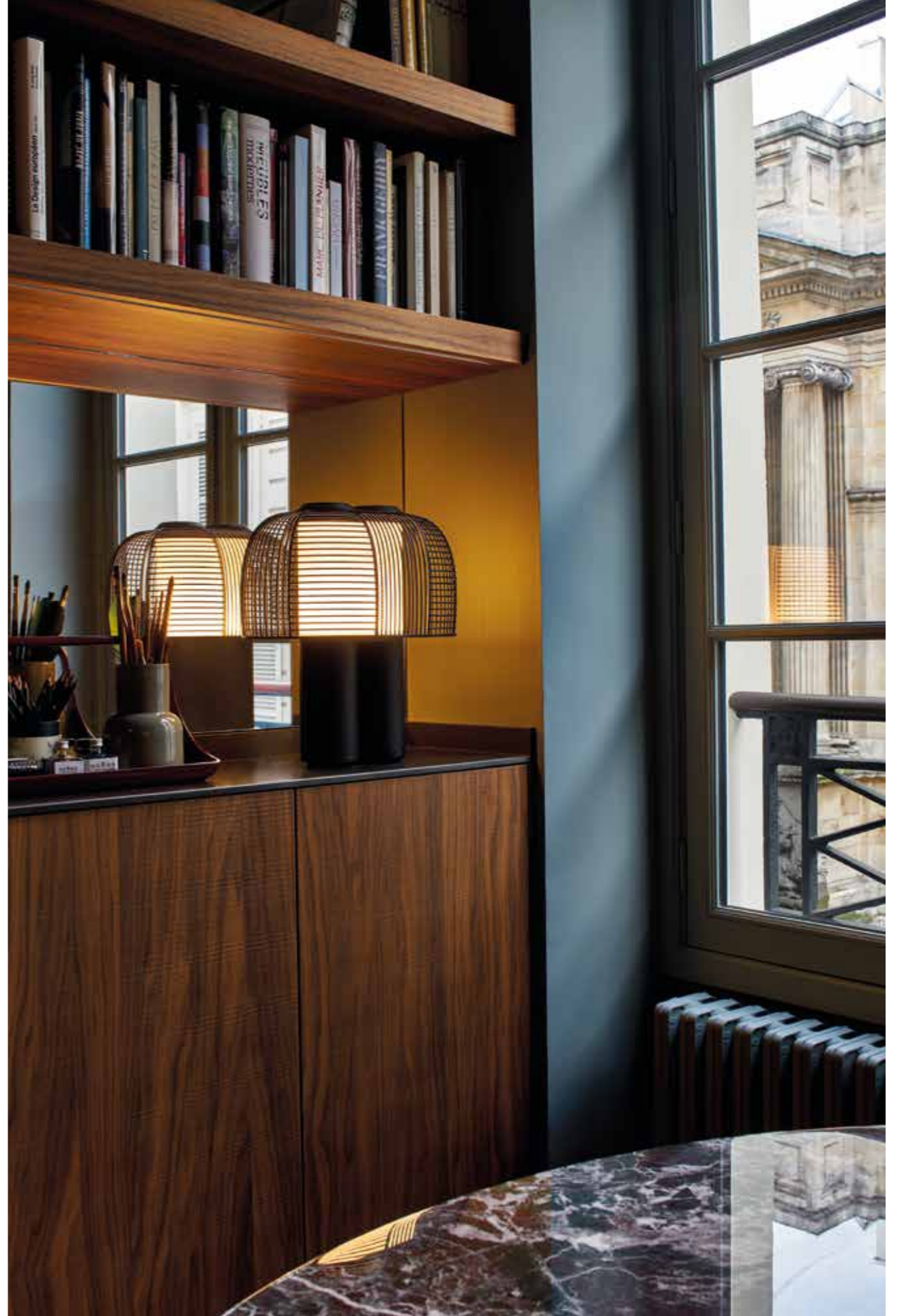

Left and right pages: YASUKE





*Left and right pages : YASUKE*



*Left and right pages: YASUKE*





› LAMPE À RÊVER

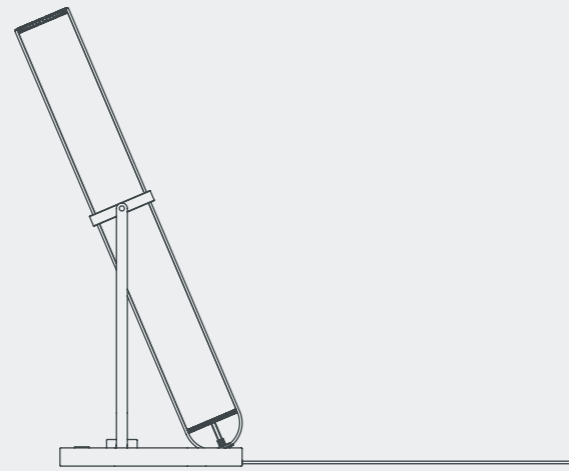

LA LAMPE FRECHIN

# LA LAMPE FRECHIN™

de Jean-Louis Frechin

**NEW**  
**LAMPES À RÊVER**  
LAMPS TO DREAM BY

# LA LAMPE FRECHIN™

de Jean-Louis Frechin

Jean-Louis Frechin



Jouant avec les contrastes entre matérialité et immatérialité, présence, absence, et révélation de la lumière, la Lampe Frechin propose une expérience sensible de l'optique entre science et magie. En confrontant des matériaux intemporels (marbre, verre, aluminium), et une approche poétique de la technologie, elle illumine autant qu'elle irradie les espaces. Jean-Louis Frechin

**English** • Playing with the contrasts between materiality and immateriality, presence, absence, and revelation of light, la Lampe Frechin offers a sensitive experience of optics between science and magic. By confronting timeless materials (marble, glass, aluminum), and a poetic approach to technology, it illuminates as much as it irradiates spaces. Jean-Louis Frechin

**Deutsch** • Im Spiel mit Kontrasten zwischen Materialität und Immaterialität, Anwesenheit, Abwesenheit und Offenbarung des Lichts schafft die La Lampe Frechin ein sensibles Erleben von Optik zwischen Wissenschaft und Magie. Durch die Konfrontation von zeitlosen Materialien (Marmor, Glas, Aluminium) und einem poetischen Einsatz der Technologie beleuchtet und bestrahlt sie Räume gleichzeitig. Jean-Louis Frechin

**Italiano** • Giocando con i contrasti tra materialità immaterialità, presenza, assenza, e rivelazione della luce, la lampada Frechin propone un'esperienza sensibile dell'ottica tra scienza e magia. Confrontando dei materiali intemporeali (marmo, vetro, alluminio), e un approccio poetico della tecnologia, illumina tanto quanto irradia gli spazi. Jean-Louis Frechin

**Español** • Jugando con los contrastes entre lo material y lo inmaterial, la presencia, la ausencia y la revelación de la luz, la Lámpara Frechin ofrece una experiencia sensible de la óptica entre la ciencia y la magia. Al confrontar materiales intemporales (mármol, vidrio, aluminio) y un enfoque poético de la tecnología, ella ilumina tanto como irradia los espacios. Jean-Louis Frechin

Right page: LA LAMPE FRECHIN





Left and right pages : LA LAMPE FRECHIN





Left and right pages: LA LAMPE FRECHIN

› WALL, PENDANT  
& TABLE  
LAMPS

**PAN**  
Simon Schmitz



PAN  
NEW

**MIDNIGHT**  
Stéphanie Gayet

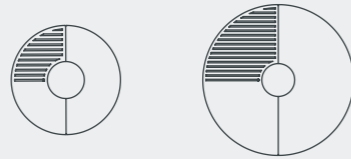

MIDNIGHT 325  
NEW

MIDNIGHT 505  
NEW

**DELUMINA**  
Giulia Liverani



DELUMINA  
WALL 250  
NEW

DELUMINA  
WALL 320  
NEW

**BORELY**  
Éric Gizard



BORELY  
NEW

**ROSALIE**  
Julie Fullet



ROSALIE  
NEW

**RESPIRO WALL**  
Philippe Nigro



RESPIRO  
WALL M  
NEW

RESPIRO  
WALL L  
NEW

**MAP 1 & MAP 1 L**  
Éric de Dormael

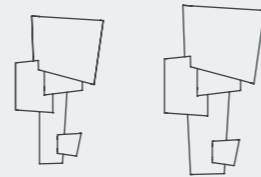

MAP 1  
NEW

MAP 1 L  
NEW

**COLLECTION CORDLESS**  
Éric de Dormael  
Dominique Perrault & Gaëlle Lauriot-Prévost

**VVV**  
Vantot

**MAP 2**  
Éric de Dormael

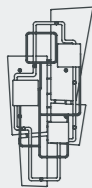

MAP 2

**ITS WALL**  
Dominique Perrault & Gaëlle Lauriot-Prévost

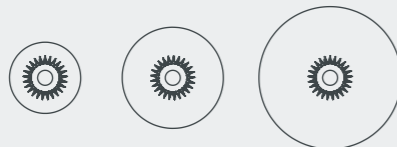

ITS 190

ITS 270

ITS 380

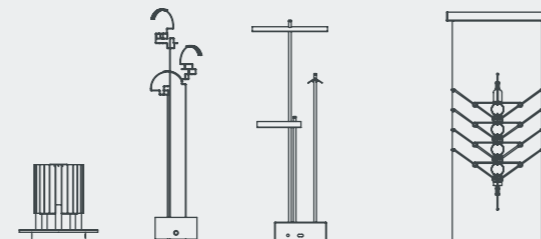

ITS WALL

BOUCLE

KNOKKE

VV

# ATMO- SPHERICS™

NEW  
ATMOSPHERICS  
COLLECTION



# ATMO-SPHERICS™

La lumière des « Atmospherics » nous invite à voir sans voir. Les ambiances électriques laissent place au calme. La lumière douce et rassurante rassemble... La timidité s'enivre, la lumière... Vivre sans modération... Derrière ces ambiances délicates se cachent les magiciens : Simon Schmitz, Stéphanie Cayet, Éric Gizard, Julie Fullet, Philippe Nigro, Guilia Liverani, Éric de Dormael, Dominique Perrault & Gaëlle Lauriot-Prévoist, Vantot.

**English** • The light from « Atmospherics » invites us to see, without seeing. Electric atmospheres give way to tranquility. A calm and reassuring light brings us together. Our reserve recedes, the light... To be lived, to the full... Behind the curtain of these sophisticated atmospheres, magicians are hidden: Simon Schmitz, Stéphanie Cayet, Éric Gizard, Julie Fullet, Philippe Nigro, Guilia Liverani, Éric de Dormael, Dominique Perrault & Gaëlle Lauriot-Prévoist, Vantot.

**Deutsch** • Das Licht von « Atmospherics » lädt uns ein, zu sehen, ohne zu sehen. Elektrische Atmosphären weichen der Stille. Ein ruhiges und beruhigendes Licht bringt uns zusammen. Unsere Zurückhaltung weicht, das Licht... Gelebt werden, in vollen Zügen... Hinter dem Vorhang dieser raffinierten Atmosphären verbergen sich Magier: Simon Schmitz, Stéphanie Cayet, Éric Gizard, Julie Fullet, Philippe Nigro, Guilia Liverani, Éric de Dormael, Dominique Perrault & Gaëlle Lauriot-Prévoist, Vantot.

**Italiano** • La luce delle « Atmospherics » ci invita a vedere senza vedere. Le atmosfere elettriche lasciano posto alla calma. La luce dolce e rassurante unisce le persone. La timidezza si inebria, la luce... A vivere senza moderazione. Dietro queste atmosfere delicate, si nascondono i maghi: Simon Schmitz, Stéphanie Cayet, Éric Gizard, Julie Fullet, Philippe Nigro, Guilia Liverani, Éric de Dormael, Dominique Perrault & Gaëlle Lauriot-Prévoist, Vantot.

**Español** • La luz de las "Atmospherics" nos invita a ver sin ver. Los ambientes eléctricos dan paso a la calma. La suave y reconfortante luz une a las personas. La timidez se emborracha, la luz... A vivir sin moderación... Detrás de estos ambientes delicados se esconden los magos: Simon Schmitz, Stéphanie Cayet, Éric Gizard, Julie Fullet, Philippe Nigro, Guilia Liverani, Éric de Dormael, Dominique Perrault & Gaëlle Lauriot-Prévoist, Vantot.



1. Simon Schmitz
2. Stéphanie Cayet
3. Éric Gizard
4. Julie Fullet,
5. Philippe Nigro
6. Guilia Liverani
7. Éric de Dormael
8. Dominique Perrault & Gaëlle Lauriot-Prévoist
9. Vantot

› **PAN**  
de Simon Schmitz



*Left and right pages: PAN*



› **MIDNIGHT**  
de Stéphanie Gayet



Left and right pages: MIDNIGHT 505 SOLID



2 x MIDNIGHT 325 STRIPES  
+ MIDNIGHT 505 SOLID



› **DELUMINA**  
de Giulia Liverani

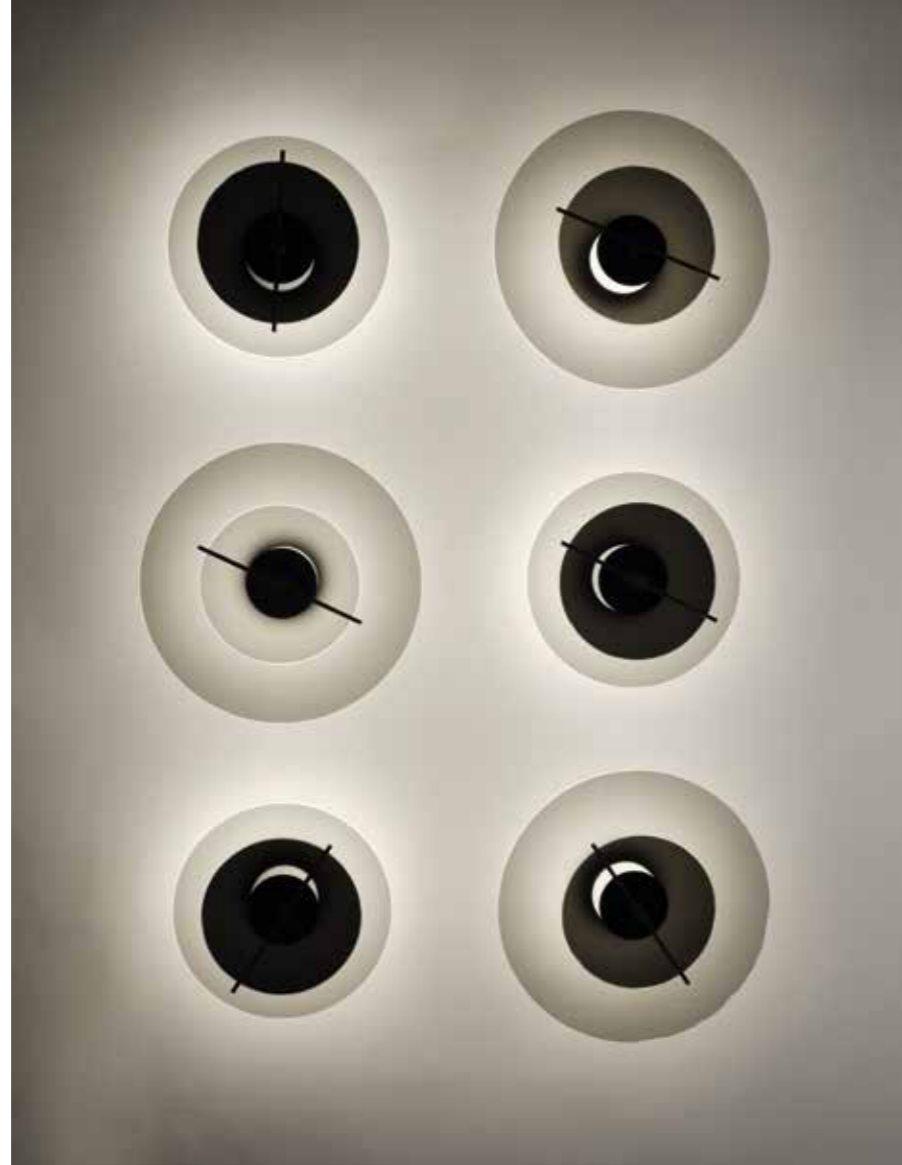

Left page: DELUMINA 250 + DELUMINA 320  
Right page: DELUMINA 320

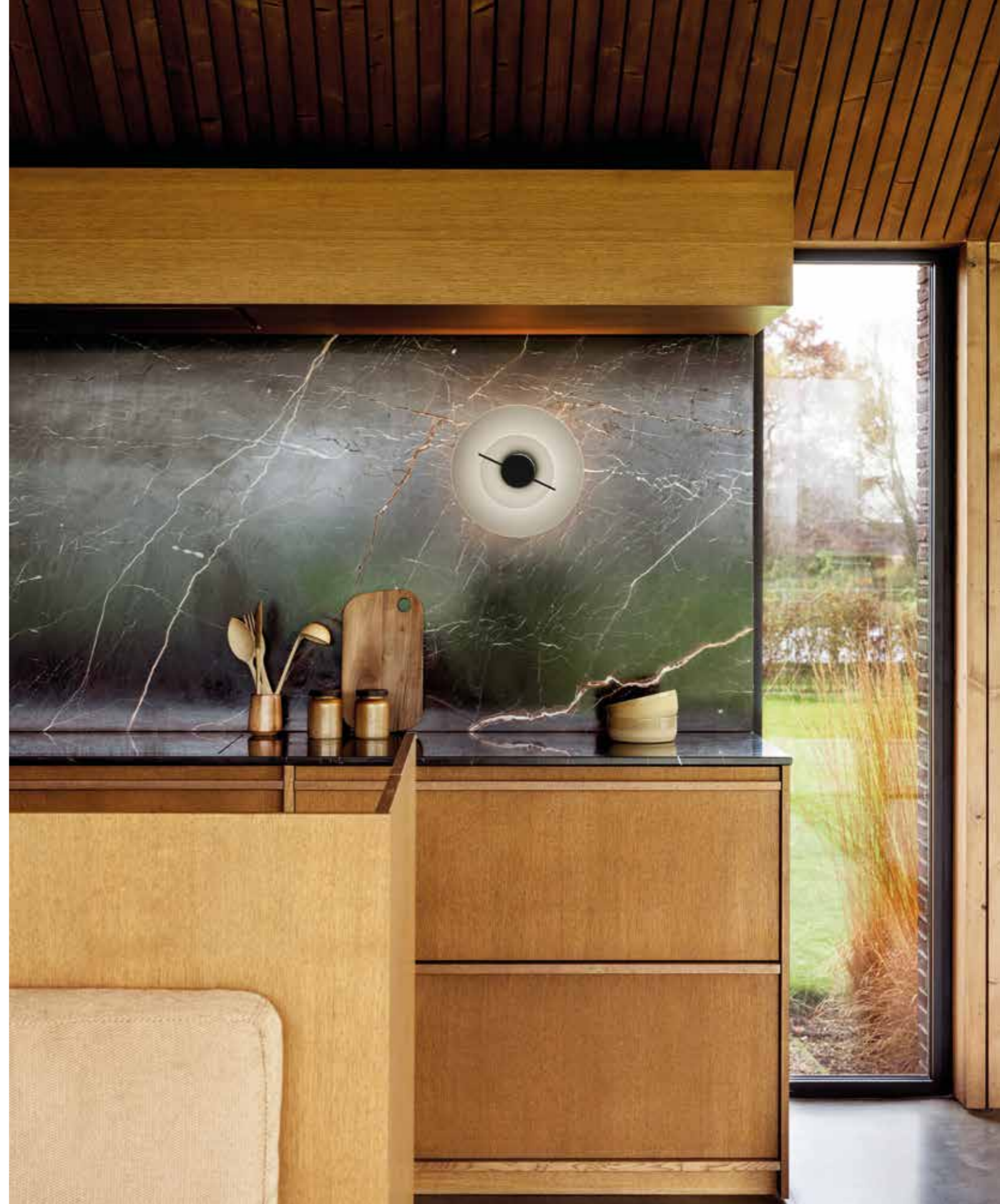



› **BORELY**  
de Eric Gizard



*Left page*  
BORELY BLACK

*Right page*  
BORELY GOLD





› **ROSALIE**  
de Julie Fullet



Left and right  
pages:  
ROSALIE

› **RESPIRO WALL**  
de Philippe Nigro



Left and right pages:  
RESPIRO WALL L



› **MAP 1 - MAP 1L - MAP 2**  
d'Éric de Dormael



Left page  
MAP 2

Right page  
MAP 1



› **ITS 190 - ITS 270 - ITS 380**

de Dominique Perrault & Gaëlle Lauriot-Prévost



Left page  
ITS W 270 SILVER-GOLD  
+ ITS W 190 SILVER-GOLD  
+ ITS SPACER 1

Right page  
ITS W 270 GOLD-SILVER





› **COLLECTION CORDLESS**

de Dominique Perrault & Gaëlle Lauriot-Prévoist  
et d'Éric de Dormael

**LAMPES SUR BATTERIE**



ITS TABLE GOLD-GOLD - Dominique Perrault & Gaëlle Lauriot-Prévoist



ITS TABLE SIL-SIL - Dominique Perrault & Gaëlle Lauriot-Prévoist



BOUCLE - Éric de Dormael



KNOCKE - Éric de Dormael



KNOKKE  
+ ITS TABLE  
+ BOUCLE



› **VVV**  
de Vantot



*Left and right pages: VVV*





TOBO C65

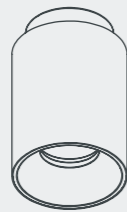

TOBO C85



TOBO C85 DIAG

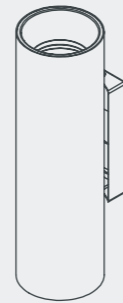

TOBO W65

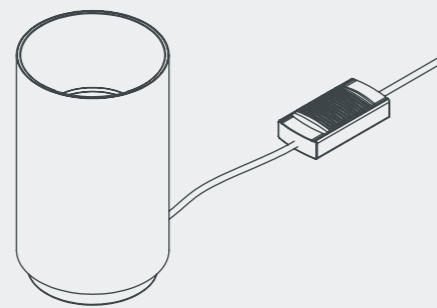

TOBO FLOOR

# TOBO™

de DCWéditions

**NEW**  
**OUTILS DE LUMIÈRE**  
LIGHTING TOOLS



# TOBO™

de DCWéditions

Le luminaire est un objet bavard.  
Mais il faut savoir parfois rester silencieux.

**TOBO** est une gamme de compléments utiles qui soutient l'éclairage. **TOBO** prend appui au plafond jouant l'alliance des diamètres. Une collection sobre, classique avec des détails que l'œil sait apprécier.

## **TOBO FLOOR**

Cette solution facile avec un variateur intégré, donne du relief à l'espace en proposant une ambiance lumineuse chaleureuse, presque théâtrale.

**English** • Lamps are like village gossips: sometimes you have to know when to stay quiet.

**TOBO** is a range of useful complements that supports lighting. **TOBO** is supported by the ceiling playing the alliance of diameters.

A sober collection, classic with catchy-eye details.

## **TOBO FLOOR**

This easy to use solution with its built-in dimmer, adds depth to any space with its warm, almost theatrical glow.

**Deutsch** • Die Leuchte ist ein auffälliges Objekt. Aber manchmal muss man auch wissen, wie man diskret bleibt. **TOBO** ist eine Reihe von nützlichen Ergänzungen, die Beleuchtung unterstützt.

**TOBO** wird von der Decke getragen und spielt mit der Allianz der Durchmesser. Eine schlichte Kollektion, klassisch mit auffälligen Details.

## **TOBO FLOOR**

Diese einfache Lösung mit integriertem Dimmer lockert den Raum auf, indem sie eine warme, fast theatralische Lichtatmosphäre schafft.

**Italiano** • Gli apparecchi sono come i pettegolezzi nei villaggi : qualche volta devi capire quando stare zitto. **TOBO** è una gamma di accessori utili a supporto dell'illuminazione. **TOBO** è sostenuto dal soffitto e gioca sull'alleanza dei diametri. Una collezione sobria, classica e con dettagli accattivanti.

## **TOBO FLOOR**

Questa soluzione facile da usare con il suo dimmer integrato, aggiunge profondità a qualsiasi spazio con il suo bagliore caldo, quasi teatrale.

**Español** • La luz es un objeto hablador. Pero a veces hay que saber callar.

**TOBO** es una gama de complementos útiles que favorecen a la iluminación. **TOBO** se apoya contra el techo jugando la alianza de diámetros.

Una colección sobria, clásica con detalles que la vista sabe apreciar.

## **TOBO FLOOR**

Esta sencilla solución, con un variador integrado, da alivio al espacio al ofrecer una atmósfera de luz cálida, casi teatral.



TOBO W65 BR + TOBO C85 BR + TOBO C65 BR



*Above*  
TOBO C85 DIAG BL  
+ TOBO C65 BL  
+ TOBO C85 BL  
+ TOBO W65 BL  
  
*Below*  
2 x TOBO FLOOR BL & WH



*Above*  
TOBO C85 DIAG  
WH  
  
*Below*  
Drawing of TOBO  
FLOOR BL





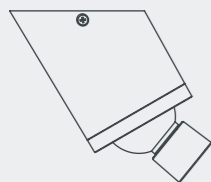

VISION 20/20

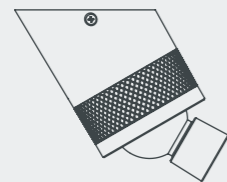

VISION 20/20  
SW

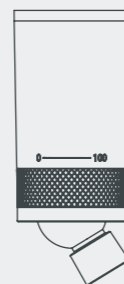

VISION 20/20  
OMNI

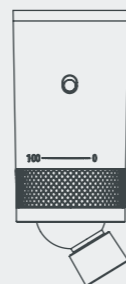

VISION 20/20  
OMNI SW



VISION 20/20 FLOOR

# VISION 20/20™

de DCWéditions

**NEW**  
**OUTILS DE LUMIÈRE**  
LIGHTING TOOLS

# VISION 20/20™

de DCWéditions

Nos yeux sont soumis à une augmentation du stress. 5 heures par jour, les yeux sont rivés sur des écrans. Dès 30 ans, la fatigue visuelle peut apparaître. La vue ne tolère pas la médiocrité.

SANS un bon éclairage:

Les yeux piquent

Le temps de lecture diminue

Les maux de tête apparaissent

Vision 20/20 permet :

1. D'éclairer avec précision
2. De régler l'intensité lumineuse adaptée à votre vue
3. De réduire la fatigue oculaire

**English** • Our eyes are under increased levels of stress. 5 hours a day, our eyes are glued to screens. From the age of 30, visual fatigue can appear. Vision does not tolerate mediocrity.

WITHOUT good lighting:

Eyes are itchy/stinging

Reading time reduces

Headaches appear

The performance of Vision 20/20 allows you to:

1. Illuminate your spaces with precision
2. Adjust the light intensity to suit your eyesight
3. Reduce glare from tablets

**Deutsch** • Unsere Augen stehen unter erhöhtem Stress. 5 Stunden lang sind unsere Augen jeden Tag auf Bildschirme gerichtet.

Ab dem 30. Lebensjahr kann visuelle Ermüdung auftreten. Das Sehen verträgt keine Mittelmäßigkeit. OHNE gute Beleuchtung:

Die Augen brennen

Die Lesezeit verkürzt sich

Kopfschmerzen treten auf

Vision 20/20 ermöglicht: 1. Mit Präzision zu beleuchten. 2. Die Lichtintensität an Ihr Sehvermögen anzupassen. 3. Blendung durch Tablets zu reduzieren

**Italiano** • E se i pianeti non fossero altro che delle bolle di sal nostri occhi sono sottoposti a maggiore stress. 5 ore al giorno, i nostri occhi sono inchiodati sugli schermi. Dall'età di 30 anni, possono comparire segni di affaticamento visivo. La vista non tollera la mediocrità.

SENZA una buona illuminazione:

Gli occhi bruciano

Il tempo di lettura diminuisce

Insorge il mal di testa

Le prestazioni di Vision 20/20 consentono di :

1. Illuminare con precisione. 2. Regolare l'intensità della luce adatta alla tua vista. 3. Ridurre l'abbagliamento dai tablet

**Español** • ¿Nuestros ojos están expuestos a una aumentación de estrés. 5 horas al día, tenemos los ojos fijos en una pantalla. A partir de los 30 años puede aparecer fatiga visual. La vista no tolera la mediocridad.

SIN una buena iluminación:

Los ojos se irritan

El tiempo de lectura disminuye

Aparacen dolores de cabeza

Vision 20/20 permite: 1. Iluminar con precisión

2. Ajustar la intensidad luminosa para adaptarla a su vista. 3. Reducir la fatiga visual







VISION 20/20 FLOOR





*Left page*  
VISION 20/20 OMNI

*Right page*  
VISION 20/20 FLOOR



› **VISION 20/20**  
BEDSIDE



**VISION 20/20**  
(driver intégré)  
(integrated driver)



**VISION 20/20 SWITCH**  
Eyelight gradable  
(driver externe)  
  
Dimmable eyelight  
(external driver)



**VISION 20/20 OMNI**  
Eyelight gradable  
Uplight contrôlé par interrupteur externe  
(driver intégré + driver externe)  
  
Dimmable eyelight  
Uplight controlled by wall switch  
(integrated driver + external driver)



**VISION 20/20 OMNI SWITCH**  
Eyelight gradable  
Uplight contrôlé par interrupteur intégré  
(driver intégré + driver externe)  
  
Dimmable eyelight  
Uplight controlled by switch on the lamp  
(integrated driver + external driver)

**IF  
YOU  
ENJOY  
THE  
TRIP  
WELCOME  
HOME**

The way we behave.

**DCW**éditions

PARIS



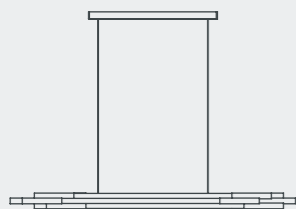

ORG P HORIZONTAL  
1300  
(7 pipes)

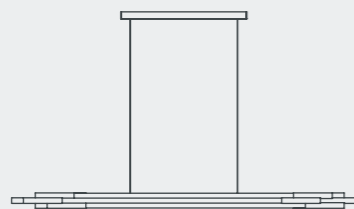

ORG P HORIZONTAL  
1600  
(7 pipes)

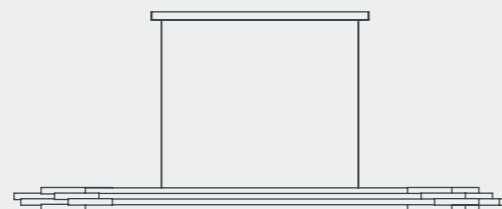

ORG P HORIZONTAL  
2000  
(12 pipes)



ORG P VERTICAL  
1300  
(7 pipes)



ORG P VERTICAL  
1600  
(7 pipes)



ORG P VERTICAL  
2000  
(12 pipes)



ORG W 1050  
(5 pipes)



ORG W 1500  
(5 pipes)

**ORG**<sup>TM</sup>  
de Sebastian Summa



Sebastian Summa

# ORG™

de Sebastian Summa

Sebastian est né en Bavière. Il a fait des études de design à l'*University of Applied Sciences* de Potsdam. Il habite à Berlin. C'est difficile de rencontrer Sebastian dans le monde du design. Il travaille dans son atelier de Berlin Est. C'est un homme de terrain. Il a démarré sa carrière comme forgeron, et a fait son apprentissage dans une usine de métallurgie avant d'aller à l'université. La ferraille, le métal et l'acier étaient son quotidien. Son atelier est hors du temps, son travail est son horloge. C'est étonnant de voir dans une

atmosphère brute, un homme sensible travaillant sur des objets délicats.

Inspiré par la science-fiction et l'astronomie, il a créé sa lampe comme une étoile filante. Elle s'appelle **ORG**. Élégante et étonnamment classique, la lampe de Sebastian passe des espaces bruts aux univers sophistiqués.

**English** • Sebastian, born in Bavaria, studied design at *University of Applied Sciences* in Potsdam. He lives in Berlin. It's difficult to meet Sebastian in the design world. He works in his studio East-Berlin and is really a doer. Before the university he started as a blacksmith, in a world of scrap iron, metal and steel. His workshop is outside time, the work is the clock. It's interesting to see in a rough surroundings, a sweet man, working on delicate objects.

Influenced by science fiction and astronomy, he built the lamp like a shooting star. Its name is **ORG**.

Elegant, surprisingly classic which goes from rough to sophisticated environment.

**Deutsch** • Sebastian, geboren in Bayern, hat an der Fachhochschule Potsdam studiert. Er wohnt in Berlin. Es ist schwierig Sebastian in der Designwelt anzutreffen. Er arbeitet in seinem Atelier in Ostberlin und ist ein echter Macher. Vor seinem Studium hat er als Kunstschmied begonnen, in einer Welt aus Eisen-Schrott, Metall und Stahl. Seine Werkstatt ist außerhalb unserer Zeit, die Arbeit selbst ist seine

innere Uhr. Es ist interessant, mitten in einer derart rauen Umgebung, einen so liebenswerten Mann anzutreffen, in seiner sorgfältigen Arbeit an filigranen Objekten. Inspiriert von Astronomie und Science Fiction hat Sebastian eine Leuchte geschaffen, die wie ein Komet erscheint. Ihr Name ist **ORG**. Elegant und dabei überraschend klassisch, findet sie ihren Platz sowohl an rauen als auch an gepflegten Orten.

**Italiano** • Sebastian è nato in Baviera. Ha studiato design presso la *University of Applied Sciences* a Potsdam. Vive a Berlino. È difficile incontrare Sebastian nel mondo del design. Lavora nel suo atelier a Berlino Est. È un uomo pragmatico. Ha iniziato la sua carriera come fabbro e ha lavorato come apprendista in una fabbrica metallurgica prima di andare all'università. I rottami, il metallo e l'acciaio rappresentavano la sua quotidianità. Il suo atelier non conosce il tempo, il suo orologio è il suo lavoro. È stupefacente vedere in un'atmosfera così rude un uomo così dolce, che opera su oggetti delicati.

Ispirato dalla fantascienza e dall'astronomia, ha creato la sua lampada come se fosse una stella cadente. Si chiama **ORG**. Elegante e sorprendentemente classica, la lampada di Sebastian trova posto sia in ambienti rudi che in atmosfere più sofisticate.

**Español** • Sebastian nació en Baviera. Estudió diseño en la Universidad de Ciencias Aplicadas de Potsdam, y actualmente vive en Berlín. Sebastian es difícil de encontrar en el mundo del diseño. Trabaja en su taller del Berlín Oriental. Es un hombre de campo. Empezó su carrera como herrero e hizo su aprendizaje en una fábrica de metales antes de ir a la universidad. La chatarra, el metal y el acero eran parte de su vida cotidiana. En su taller no existe el tiempo, su trabajo es su reloj. Es asombroso ver en una atmósfera tan industrial a un hombre tan dulce, trabajando en objetos tan delicados. Inspirado por la ciencia ficción y la astronomía, creó su lámpara como una estrella fugaz. Se llama **ORG**. Elegante y sorprendentemente clásica, la lámpara de Sebastian encuentra su lugar tanto en entornos ásperos como en las atmósferas más sofisticadas.







*Left page*  
ORG P H 1300

*Right page*  
ORG W 1050

*Pages 124- 125*  
ORG P H 1600  
+ ORG W 1050  
+ ORG W 1500









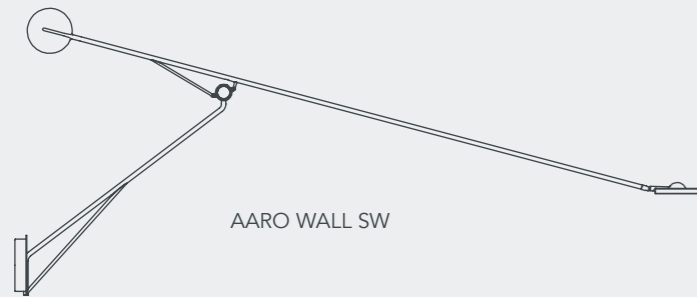

AARO WALL SW

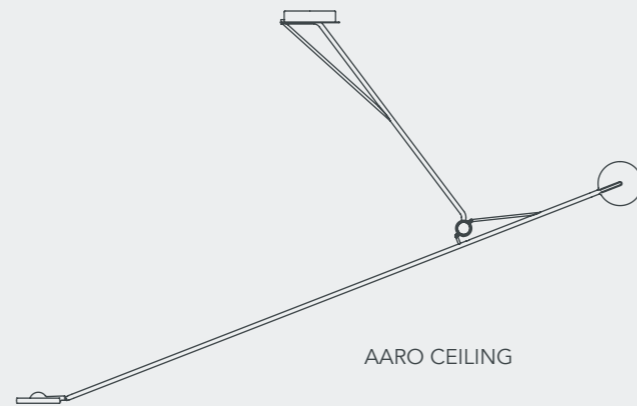

AARO CEILING

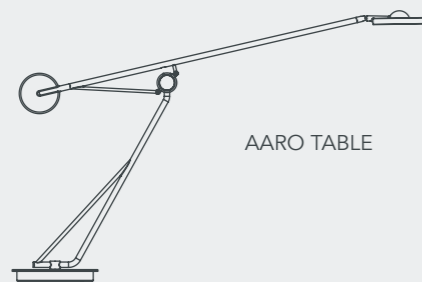

AARO TABLE

# AARO™

de Simon Schmitz



Simon Schmitz

# AARO™

de Simon Schmitz

Simon, né à Arnberg a installé son atelier à Hambourg, après avoir terminé ses études à la "School of Art".

C'est là qu'il a découvert la liberté, l'autonomie et la responsabilité du designer. "Voici ton atelier, prends un crayon, et débrouille-toi." Il a ainsi tout appris sur les formes, les matériaux, les processus et le plus

important: le contexte. "Si tu ne sais pas pourquoi tu fais ce que tu fais, ne le fais pas du tout."

Le point de départ de sa lampe **AARO** était un geste. L'envie de créer un mouvement le plus fluide possible. Ce qui l'a immédiatement guidé vers la sphère. Une sphère en guise d'articulation, qui laisse place à d'infinies directions. Une sphère qui n'a ni gauche, ni droite, ni haut, ni bas. En tant qu'élément central de la lampe, cette sphère permet à tout le reste de graviter autour d'elle. La géométrie, l'équilibre, le frottement. Tout repose sur elle. Tout la désigne.

**AARO** est un objet qui semble flotter dans l'air, gravitant autour de sa pièce centrale, comme des planètes en orbite.

Avec **AARO**, inspiré de l'anglais Aaron's rod (le bâton d'Aaron), le magicien Simon Schmitz fait léviter ses luminaires.

**English** • Simon, born in Arnberg, set up his studio in Hamburg after completing his studies at the "School of Art".

There he discovered the freedom, autonomy and responsibility to be a designer. "Here's your workshop, here's a pen, go on then." This taught him everything he needed to know about form, materials, processes and most importantly: the context. "If you don't know why you are doing what you are doing, don't bother doing it at all."

The starting point of **AARO** was a gesture. A movement. He wanted to create an as fluid motion as possible, which immediately lead him to the sphere. A sphere has so many fantastic attributes. With a sphere as a joint they are no limited directions, it has no left or right, no top or bottom. So with the sphere as the defining element of this piece, everything else "revolved" around it. The geometry, the balance, the friction. It all comes down to the sphere, visually pointing at it. The end result is an object that seems to be moved by the wind. It revolves effortless around it's centerpiece, like planets orbiting around each other.

With **AARO**, inspired by Aaron's rod, the magician Simon Schmitz makes his lamp levitate.

**Deutsch** • Simon, in Arnberg geboren, hat sein Atelier in Hamburg eingerichtet. Nachdem er sein Studium an der "School of Art". abgeschlossen hat.

Dort hat er gelernt, frei, selbständig und verantwortlich als Designer zu arbeiten. "Das ist Dein Atelier, nehme einen Stift und mache etwas draus." So hat er alles über Formen, Materialien, Prozesse und am wichtigsten über die Zusammenhänge gelernt. "Wenn Du nicht weißt, warum Du das tust, was Du tust, fasse es nicht an."

Der Ausgangspunkt seiner Leuchte **AARO** ist eine Bewegung. Die Lust, eine Bewegung zu schaffen - so fließend wie möglich. Dieser Gedanke hat ihn gleich zur Idee einer Sphäre geführt. Eine Sphäre als Gelenkorgan, das Raum in allerlei Richtungen bietet. Eine Sphäre, die weder links, rechts, oben oder unten kennt. Die Sphäre ist das zentrale Element der Leuchte und alle anderen Elemente richten sich nach ihr. Die Geometrie, das Gleichgewicht, die Reibung. Alles hängt von ihr ab. Alle zeigen auf sie.

**AARO** ist ein Objekt, das in der Luft zu schweben scheint, indem sich alles um sein Zentralelement dreht, wie Planeten in ihrer Umlaufbahn.

Mit **AARO**, inspiriert aus dem englischen Begriff Aaron's rod (Aarons Stab), lässt der Zauberer Simon Schmitz seine Leuchten schweben.

**Italiano** • Simon, nato ad Arnberg, ha fondato il proprio atelier ad Amburgo, dopo aver completato gli studi presso la "School of Art".

È stato lì che ha avuto modo di scoprire la libertà, l'autonomia e le responsabilità del designer. "Ecco il tuo atelier, prendi una matita, e arrangiati." Ha così imparato tutto sulle forme, i materiali, i processi e sulla cosa più importante: il contesto. "Se non sai perché fai ciò che fai, non farlo affatto."

Il punto di partenza della sua lampada **AARO** risiede in un gesto. Il desiderio di creare un movimento il più fluido possibile. Il che lo ha immediatamente guidato verso la sfera. Una sfera come articolazione, che lascia il posto a direzioni infinite. Una sfera che non ha né sinistra, né destra, né parte superiore, né parte inferiore. In quanto elemento centrale della lampada, questa sfera consente a tutto il resto di gravitare attorno a essa. La geometria, l'equilibrio, l'attrito. Tutto si fonda su di lei. Tutto la rivela.

**AARO** è un oggetto che sembra fluttuare nell'aria, ruotando attorno al suo pezzo centrale, come i pianeti in orbita.

Con **AARO**, ispirato dall'inglese Aaron's rod (la bacchetta di Aaron), il mago Simon Schmitz fa levitare le sue lampade.

**Español** • Simon, nacido en Arnberg, abrió su taller en Hamburgo tras terminar sus estudios en la "School of Art". Fue entonces cuando descubrió la libertad, la autonomía y la responsabilidad del diseñador. "Aquí está tu taller, toma un lápiz y arréglatelas." Así aprendió todo sobre las formas, los materiales, los procesos y lo más importante: el contexto. "Si no sabes por qué haces lo que haces, no lo hagas en absoluto."

El punto de partida de su lámpara **AARO** fue un gesto. El deseo de crear un movimiento lo más fluído posible. Lo que lo llevó inmediatamente a la esfera. Una esfera en forma de articulación, dando paso a infinitas direcciones. Una esfera que no tiene ni izquierda, ni derecha, ni arriba, ni abajo. Como elemento central de la lámpara, esta esfera permite que todo lo demás grave a su alrededor. La geometría, el equilibrio, la fricción. Todo depende de ella. Todo la señala.

**AARO** es un objeto que parece flotar en el aire, gravitando alrededor de su pieza central, como planetas en órbita. Con **AARO**, inspirado en el inglés Aaron's rod (el bastón de Aaron), el mago Simon Schmitz hace levitar sus luminarias.





AARO WALL SW



AARO WALL SW



AARO WALL SW



Left page  
AARO CEILING



Right page  
AARO WALL SW





Left page  
AARO WALL SW

Right page  
AARO TABLE

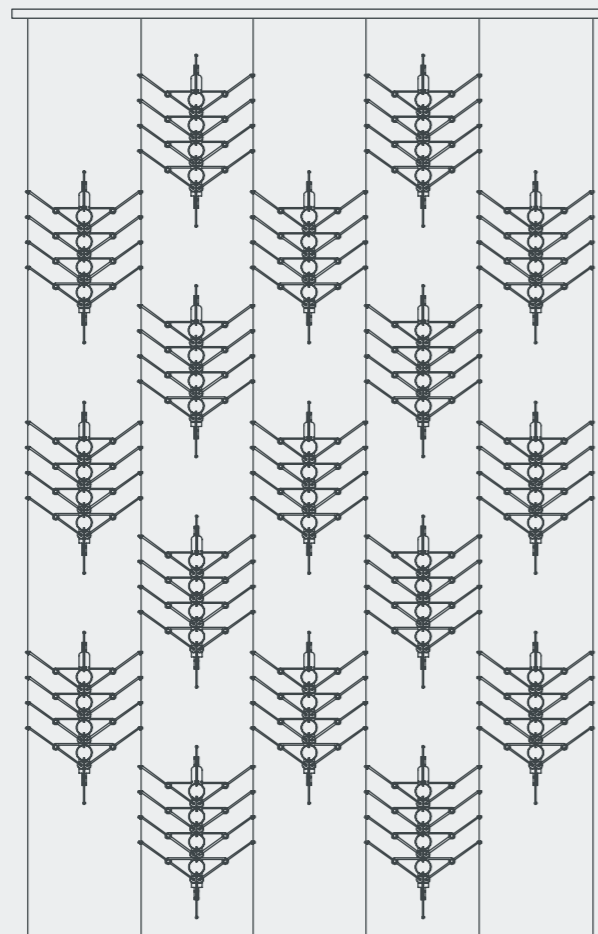

VV

VV™  
de Vantot





Esther et Sam en couple dans la vie comme dans leur atelier, sont diplômés de Design Academy of Eindhoven. Ils ont fondé leur studio en 2014 à Eindhoven.

Leur domaine de prédilection est la lumière. Ils développent leurs luminaires jusqu'aux moindres détails. Ils ne se contentent pas de dessiner. Ils prototypent et réalisent eux-mêmes, partageant un amour pour la mécanique et le mouvement. Leur approche mathématique du design les incite à construire en contournant l'évidence, pour réinventer les objets.

Lorsqu'on leur demande ce qui les inspire, ils répondent sans limite: "Tout! Nous sommes curieux. Observer le monde nous inspire."

Et pourtant, leurs luminaires invitent aux voyages à bord de vaisseaux à la découverte de notre galaxie. En présence d'un "rideau" de VVV, au-delà d'une élégance sans référence, une énergie se dégage. La vitesse et la puissance prennent possession du vide.

**English** • Esther and Sam, both graduates of the Design Academy of Eindhoven, are partners, both in life and in their studio. They founded their Eindhoven studio in 2014.

Their favourite area to work with is light. They work on their light fittings down to the last detail. They do not just draw. They also prototype and create, sharing a love for mechanics and movement. Their mathematical approach to design encourages them to avoid the obvious, to reinvent objects when they build.

## de Vantot

When asked what inspires them, they respond without hesitation: "Everything! We are curious. We are inspired by observing the world."

And yet their light fittings seem to be invitations to travel aboard ships, setting out to discover our galaxy. In the presence of a "curtain" of VVV in addition to its unmatched elegance, there is an emergent energy. Speed and power take over the void.

**Deutsch** • Esther und Sam sind ein Paar zuhause und in ihrem Atelier. Beide haben ein Diplom der Design Academy of Eindhoven. Ihr Studio haben sie 2014 in Eindhoven gegründet.

Ihre Leidenschaft ist das Licht. Sie entwickeln Leuchten bis in die kleinsten Details. Sie zeichnen nicht nur. Sie erstellen Prototypen und setzen selbst ihre Entwürfe um. Beide teilen eine große Liebe für Mechanik und Motorik. Ihr mathematischer Designansatz bringt sie dazu, Objekte zu schaffen, indem sie das Selbstverständliche umgehen und Objekte neu erfinden.

Wenn man sie nach ihrer Inspirationsquelle fragt, antworten sie unbefangen: "Alles! Wir sind neugierig. Es inspiriert uns, die Welt zu beobachten."

Ihre Leuchten laden zu Entdeckungsreisen in unserer Galaxie an Bord eines Raumschiffs ein. Vor einem "Vorhang" von VVV spürt man, wie sich eine besondere Aura entfaltet. Geschwindigkeit und Kraft nehmen Besitz vom leeren Raum.

**Italiano** • Esther e Sam, in coppia nella vita come nel loro atelier, si sono diplomati alla Design Academy di Eindhoven. Nel 2014, a Eindhoven, hanno fondato il loro studio.

Il settore che prediligono è la luce. Sviluppano le loro lampade nei minimi dettagli. Non si accontentano di disegnare. Creano prototipi e li realizzano loro stessi, dal momento che condividono la passione per la meccanica e il movimento. Il loro approccio matematico al design li spinge a costruire evitando le cose banali, per reinventare gli oggetti.

Quando si chiede loro cosa li ispira, rispondono senza limiti: "Tutto! Siamo curiosi. Osservare il mondo, ci ispira."



E per questa ragione, le loro lampade invitano a viaggiare a bordo di navicelle alla scoperta della nostra galassia. In presenza di una "tendina" di VVV, oltre a un'eleganza senza riferimenti, si sprigiona energia. La velocità e la potenza si impossessano del vuoto.

**Español** • Esther y Sam son pareja, tanto de vida como en su taller, y se graduaron en la Academia de Diseño de Eindhoven, ciudad en la que fundaron su estudio en 2014.

Su área predilecta es la luz. Desarrollan sus luminarias hasta el último detalle. No se contentan con diseñar. Ellos mismos prototipan y producen, compartiendo su amor por la mecánica y el movimiento. Su enfoque matemático del diseño les lleva a construir, evitando lo obvio, para reinventar objetos.

Cuando se les pregunta qué les inspira, responden sin límites: "¡Todo! Somos muy curiosos. Observar el mundo nos inspira."

Sin embargo, sus lámparas invitan a viajes a bordo de naves para descubrir nuestra galaxia. En presencia de una "cortina" de VVV, más allá de una elegancia sin precedentes, se desprende una energía. La velocidad y la potencia toman posesión del vacío.



Left and right pages: VVV





Left and right pages : VVV

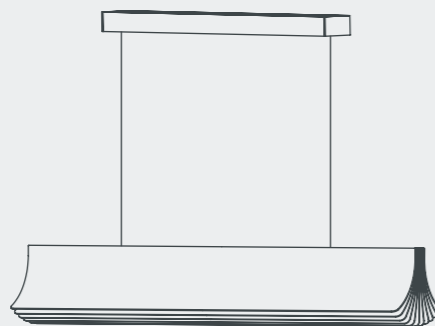

RESPIRO PENDANT 900

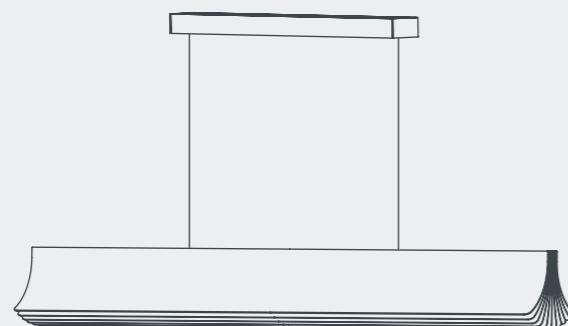

RESPIRO PENDANT 1200

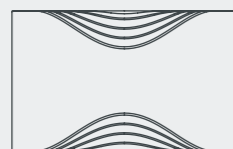

RESPIRO WALL M

NEW



RESPIRO WALL L

NEW

# RESPIRO™

de Philippe Nigro



# RESPIRO™

de Philippe Nigro

Philippe, designer français, vit entre Paris et Milan. Après des études en design industriel et un diplôme d'arts appliqués à l'école Boule de Paris, il débute aux côtés de Michele De Lucchi puis crée son studio pour donner vie à ses idées, ses objets, ses projets d'architecture et de scénographie d'espace.

Philippe nous ouvre son journal intime avec **Respiro** (souffle en italien).

Légèreté, douceur, envie de se retrouver, partager ses histoires, refaire le monde... La lumière de **Respiro** fait du bien! à quoi? à tout!

**English** • Philippe, a French designer, lives between Paris and Milan. After studying industrial design and a degree in applied arts at the Boule school in Paris, he started with Michele De Lucchi and then set up his studio to bring his ideas to life: his objects, his architectural projects and scenography of space.

Philippe opens his personal journal to show us **Respiro** (Italian for breath).

Lightness, sweetness, desire to be together, sharing stories, changing the world... **Respiro** light is good for you! For what? Everything!

**Deutsch** • Der französische Designer Philippe lebt in Paris und Mailand. Nach seinem Industriedesign-Studium und einem Diplom an der Boule-Kunsthochschule für Angewandtes Design in Paris arbeitete er zunächst bei Michele De Lucchi und gründete später ein eigenes Atelier, um seine Ideen, seine Objekte, seine Architektur- und szenografischen Raum-Projekte zum Leben zu erwecken.

Philippe öffnet für uns sein sehr persönliches Tagebuch, um uns **Respiro** (Atem auf Italienisch) zu zeigen.

Was von dieser Leuchte ausgeht ist die Leichtigkeit, die Zartheit, der Wunsch zusammen zu sein, Geschichten zu teilen, die Welt zu verändern... Die **Respiro** Licht tut einem gut! Inwiefern? In Allem!

**Italiano** • Philippe, designer francese, vive tra Parigi e Milano. Dopo aver studiato design industriale e aver conseguito un diploma in arti applicate alla scuola Boule di Parigi, ha debuttato al fianco di Michele De Lucchi e ha successivamente fondato il proprio atelier per dare vita alle proprie idee, ai propri oggetti, ai propri progetti architettonici e di scenografia dello spazio.

Philippe ci apre il suo diario personale con **Respiro**.

Leggerezza, dolcezza, desiderio di incontrarsi, di condividere le proprie storie, di cambiare il mondo... Bene, la luce di **Respiro** fa bene! A cosa? A tutto!



Philippe Nigro

**Español** • Philippe, diseñador francés, vive entre París y Milán. Al finalizar sus estudios de diseño industrial y una diplomatura en artes aplicadas en la escuela Boule de París, hace su debut junto a Michele De Lucchi y luego abre un estudio para dar vida a sus ideas, sus objetos y sus proyectos de arquitectura y escenografía espacial.

Philippe empieza su diario con **Respiro** (respiración en italiano).

Ligereza, dulzura, deseo de reencontrarse, compartir historias, cambiar el mundo...

La luz de **Respiro** es saludable. ¿Para qué? Todo!



Left page: RESPIRO PENDANT WHITE-GOLD 900

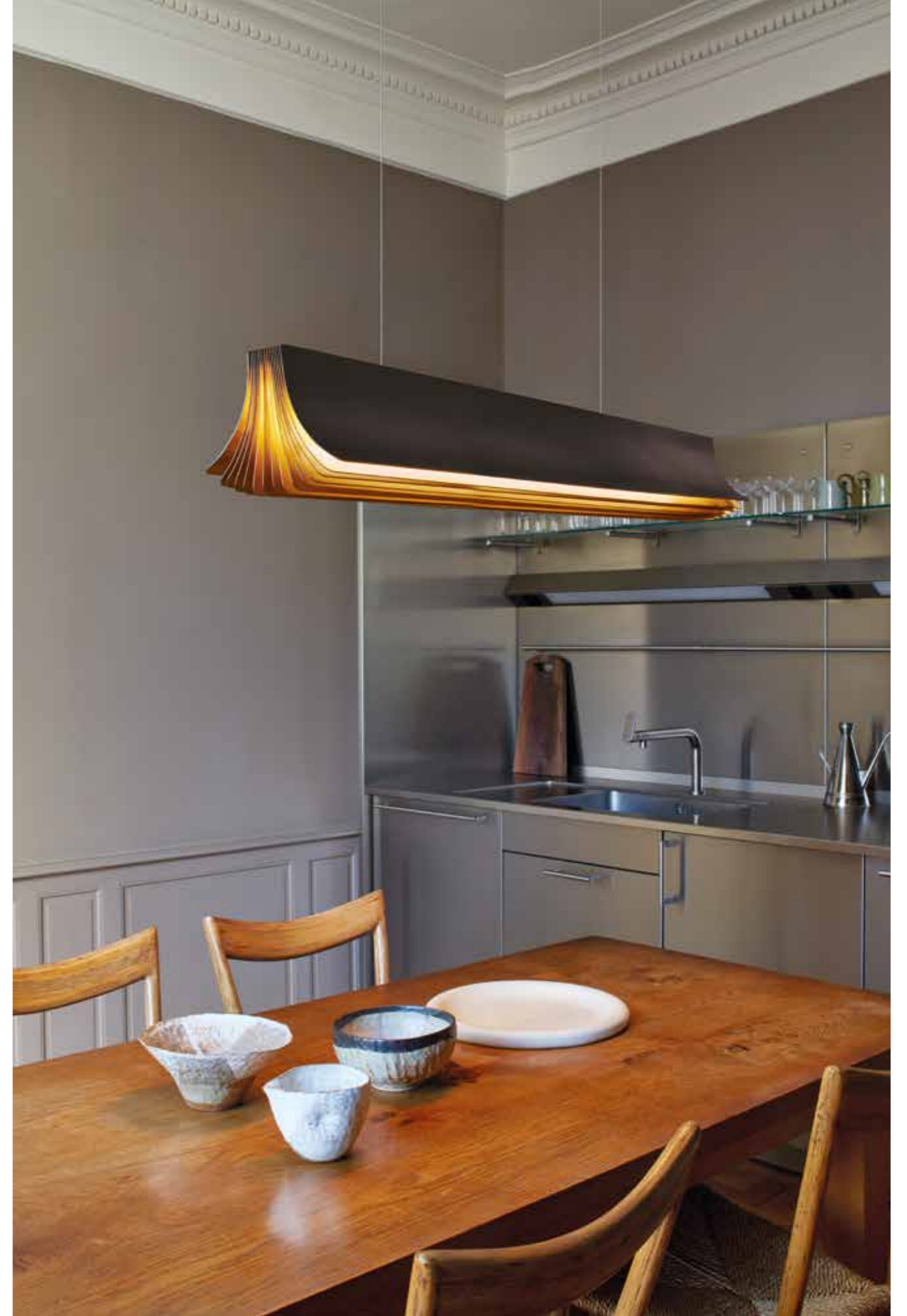

Right page: RESPIRO PENDANT BLACK-GOLD 1200





Left page: RESPIRO PENDANT GOLD-GOLD 1200

Right page: RESPIRO PENDANT GOLD-GOLD 1200 + CORDLESS BOUCLE, KNOCKE & ITS TABLE

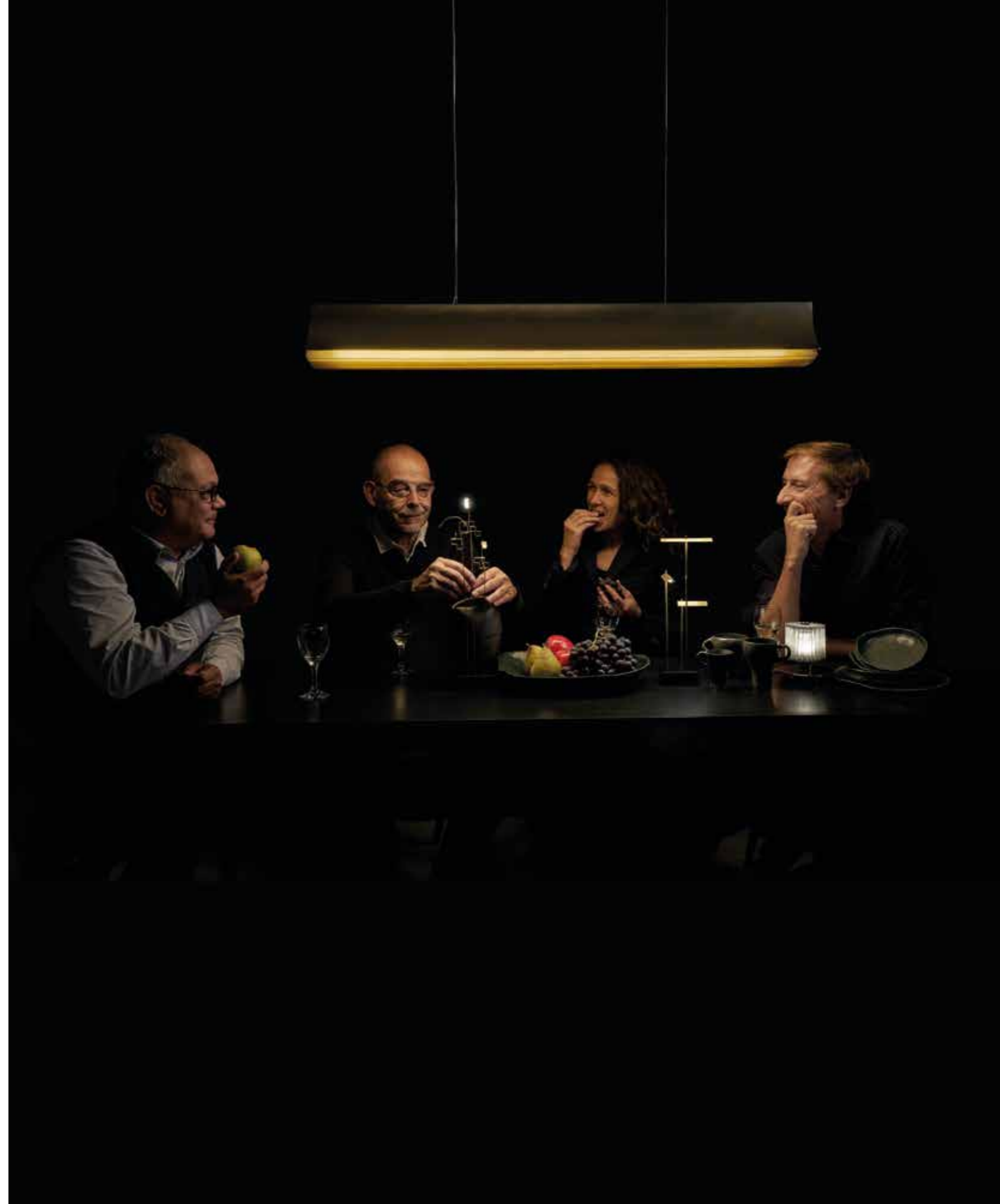



*Left page*  
RESPIRO  
PENDANT  
GOLD-GOLD  
900

*Right page*  
RESPIRO  
PENDANT  
GOLD-GOLD  
1200 +  
CORDLESS  
BOUCLE &  
KNOKKE





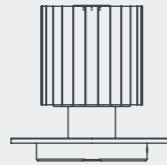

ITS TABLE  
Collection de Dominique Perrault  
et Gaëlle Lauriot-Prévost

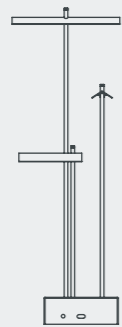

KNOCKE  
Collection d'Éric de Dormael

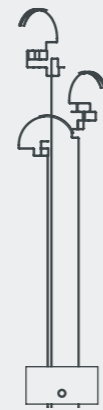

BOUCLE  
Collection d'Éric de Dormael

# COLLECTION CORDLESS™

SUR BATTERIES

BIJOUX DE LUMIÈRE  
JEWELS OF LIGHT









Pages 156 - 157  
BOUCLE  
+ ITS TABLE  
SILVER-GOLD  
+ KNOKKE

Left page  
BOUCLE

Right page  
KNOKKE





Left page  
ITS TABLE SILVER-GOLD

Right page  
BOUCLE





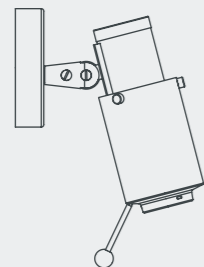

BINY SPOT

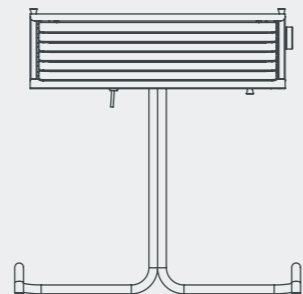

BINY TABLE

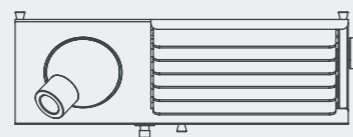
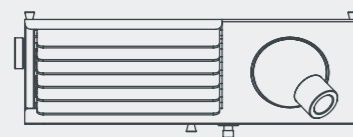

BINY BEDSIDE LEFT & RIGHT

**BINY**<sup>TM</sup>  
de Jacques Biny



Jacques Biny

# BINY™

de Jacques Biny

**Jacques Biny**, en 1955, fonde à Paris son atelier d'éclairage moderne Luminalite.

Moderne, précurseur, ce Designer-éditeur né en 1913 développe sur 30 ans près de 400 modèles. Jacques Biny, est un homme rigoureux, qui n'a cessé de travailler pour améliorer le confort par la lumière dans l'habitat. La priorité donnée à la fonction, l'économie de moyens dans la

recherche formelle suggèrent certains parallèles avec le courant artistique américain du Minimalisme apparu au milieu des années 60, ce qui explique l'engouement des collectionneurs autant aux états-Unis qu'en Europe.

Efficacité, simplicité, sobriété, élégance, refus de l'ostentatoire sont les dénominateurs communs du travail de Jacques Biny.

Ce sont pour ces qualités que nous avons choisi d'éditer les Box et le Spot de Jacques Biny.

**English** • In 1955, **Jacques Biny**, opened Luminalite, his workshop for producing modern lighting. Modern, before its time, the Designer-Manufacturer who was born in 1913 developed over 400 models during a 30 year career. Jacques Biny's hallmark was rigour and he never stopped in his quest to improve how homes were lit. Functionality was primary, the lack of superfluity in the form reminiscent of the minimalist movement that was gaining currency in American art during the 1960's, which may go to explain why his work is as popular with American collectors as it is with Europeans.

Efficiency and simplicity, restraint, elegance and modesty are the common denominators in Jacques Biny's work.

They are the same qualities that inspired us to reproduce Jacques Biny's Box lights.

**Deutsch** • **Jacques Biny**, geboren 1913, gründet 1955 in Paris sein erstes Atelier "Luminalit" zur Herstellung moderner Leuchten. Dieser Designer und Verleger entwickelt als moderner Vorläufer rund 400 Modelle in 30 Jahren.

Jacques Biny ist ein gewissenhafter Mann, der unablässig arbeitet, um den Komfort des Lebensraumes durch die Beleuchtung zu verbessern. Die

Priorität gilt der Funktion. Die Einsparung in der Formensuche evoziert einige Parallelen zur amerikanischen Stilrichtung des Minimalismus, aufgekomen in der Mitte der 60er Jahre. Diese Tatsache erklärt die Begeisterung für Biny's Modelle sowohl in Amerika als auch in Europa.

Effizienz, Schlichtheit, Zurückhaltung, Eleganz, betonte Unauffälligkeit sind die gemeinsamen Nenner der Werke Jacques Binnys.

Es sind diese Vorzüge, die uns ermutigt haben, die "Box de Lumière" von Jacques Biny zu verlegen.

**Italiano** • Nel 1955 **Jacques Biny**, fondò a Parigi il proprio laboratorio d'illuminazione moderna Luminalite.

Questo Progettista-Produttore moderno e precursore dei tempi, nato nel 1913, sviluppa nel corso di 30 anni quasi 400 modelli. Jacques Biny è un uomo rigoroso, che non ha mai smesso di lavorare per migliorare il comfort nell'abitazione attraverso l'illuminazione. La priorità data alla funzione dell'oggetto e l'economia di mezzi nella ricerca formale suggeriscono alcuni parallelismi con la corrente artistica americana del Minimalismo, comparsa nella metà degli anni Sessanta, il che ne spiega la popolarità tra i collezionisti sia negli Stati Uniti che in Europa.

Efficienza, semplicità, sobrietà, eleganza, rifiuto dell'ostentazione sono i denominatori comuni dell'opera di Jacques de Biny.

È per queste caratteristiche che abbiamo deciso di realizzare i Box de lumière di Jacques Biny.



**Español** • **Jacques Biny**, fundó en 1955 su taller de iluminación moderna Luminalite en París.

Moderno y precursor, este diseñador y editor nacido en 1913 desarrolló a lo largo de 30 años alrededor de 400 modelos. Jacques Biny es un hombre riguroso que no ha dejado de trabajar para mejorar el confort mediante la iluminación del hábitat. La prioridad que se otorga a la función y la economía de medios en la investigación formal sugieren ciertos paralelismos con la corriente artística americana del Minimalismo, aparecida a mediados de los años sesenta, lo que explica el entusiasmo de los coleccionistas tanto en Estados Unidos como en Europa.

La eficiencia, sencillez, sobriedad, elegancia y el rechazo de la ostentación son los denominadores comunes de la obra de Jacques Biny.

Estas son las cualidades por las que hemos decidido editar los Box de luz de Jacques Biny.





COLLECTION | BINY

# BINY SPOT™



*Left page*  
BINY SPOT BL-NK

*Right page*  
2 x BINY SPOT BL-NK

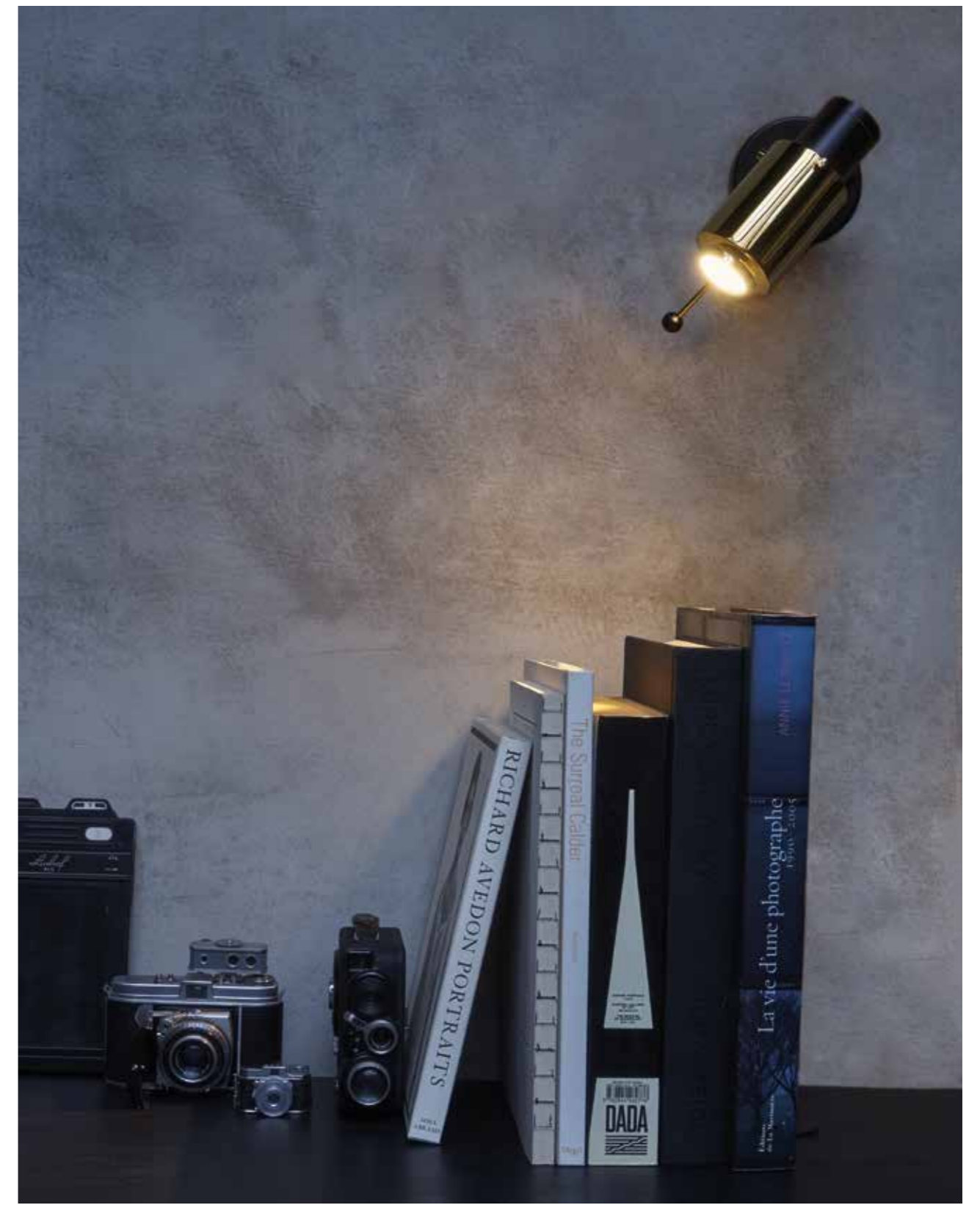

Left page: BINY SPOT BL-BL + N° 205 BL-BL | Right page: BINY SPOT BL-GOL



COLLECTION | BINY

# BINY TABLE™



Right and left pages : BINY TABLE SW BL-WH

# BINY BEDSIDE™



Left page: BINY BEDSIDE BL-WH LEFT



Right page: BINY BEDSIDE BL-WH RIGHT





Left page  
BINY BEDSIDE  
BL-WH LEFT

Right page  
BINY BEDSIDE  
BL-WH RIGHT



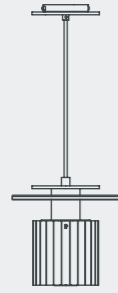

ITS P 190

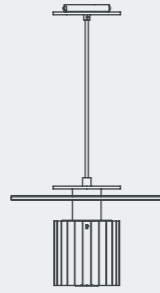

ITS P 270

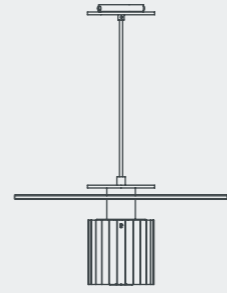

ITS P 380

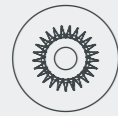

ITS W 190

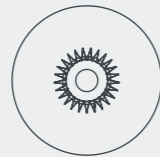

ITS W 270

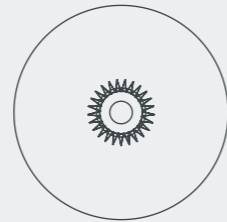

ITS W 380



ITS W 190



ITS W 270

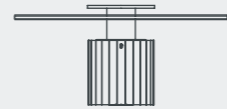

ITS W 380

# IN THE SUN™

de Dominique Perrault & Gaëlle Lauriot-Prévost



# IN THE SUN™

de Dominique Perrault  
& Gaëlle Lauriot-Prévost

## ATMOSPHERIC LAMP

Dans le cadre du réaménagement du Pavillon Dufour du Château de Versailles, **Dominique Perrault** et **Gaëlle Lauriot-Prévost** ont imaginé une collection de luminaires en hommage au Roi-Soleil.

Cette collection "**In The Sun**" (ITS) rayonne de ses ombres joyeuses et de ses lumières festives, dorées et argentées.

De la pièce éclairée éclot une atmosphère toute particulière. En applique, plafonnier ou suspension, la magie s'empare du lieu.

**English** • As part of the renovation of the Pavillon Dufour at the Chateau de Versailles, **Dominique Perrault** and **Gaëlle Lauriot-Prévost** came up with a homage to the Sun King.

The "**In The Sun**" (ITS) collection radiates festive hues of gold and silver in conjunction with softly cast shadows.

The result is a very special atmosphere in the rooms they are used to light. Whether wall-mounted, as a ceiling lamp or hanging, the result is consistently magical.

**Deutsch** • Im Rahmen der Renovierung des Pavillon Dufour im Schloss Versailles haben **Dominique Perrault** und **Gaëlle Lauriot-Prévost** eine Kollektion von Leuchten entwickelt, die eine Hommage an den Sonnenkönig darstellt. Der Anmut dieser

Kollektion "**In The Sun**" (ITS) erwächst aus den vergnügten Schatten und dem festliche gold-silberne Licht. Aus dem erleuchteten Raum entsteht eine ganz eigenwillige Atmosphäre. Ob als Wand-, Decken- oder Hängeleuchte, ein Zauber ermächtigt sich der Räumlichkeit.

**Italiano** • Nell'ambito della riqualificazione del Padiglione Dufour del Castello di Versailles, **Dominique Perrault** e **Gaëlle Lauriot-Prévost** hanno ideato una collezione di luci in omaggio al Re Sole. Questa collezione "**In The Sun**" brilla con le sue ombre allegre e le sue luci festose, dorate e argente.

Dalla stanza illuminata emerge un'atmosfera speciale. A parete, a soffitto o in sospensione, la magia prende il sopravvento.

**Español** • En el contexto de la remodelación del pabellón Dufour del castillo de Versailles, **Dominique Perrault** y **Gaëlle Lauriot-Prévost** han ideado una colección de iluminación en homenaje al Rey Sol.

La colección "**In The Sun**" (ITS) resplandece en sus felices sombras y sus luces festivas, doradas y plateadas. De la habitación iluminada surge una atmósfera especial.

En forma de aplique, plafón o suspensión, la magia ocupa el espacio.





*Left page*

Composition with:  
2x ITS W 190 SILVER-GOLD ;  
2x ITS W 270 SILVER-GOLD ;  
1x ITS W 380 SILVER-GOLD  
+ ITS SPACERS 1 et 2

*Right page*

ITS W 270 GOLD-GOLD







Left page : 2 x ITS W 270 GOLD-GOLD  
Right page : ITS W 380 SILVER-GOLD + ITS TABLE GOLD-SILVER





Left page: 2 x ITS W 270 SILVER-GOLD

Right page: ITS P 190 SILVER-SILVER + ITS P 270 SILVER-SILVER + ITS P 380 SILVER-SILVER





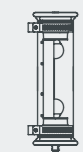

ITT  
100-350



ITT  
100-500

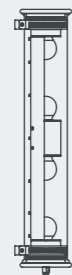

ITT  
120-700



ITT  
120-1300



ITT  
120-1300  
with Mesh



ITT  
120-700  
with Mesh



ITT  
100-500  
with Mesh

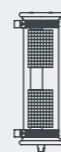

ITT  
100-350  
with Mesh

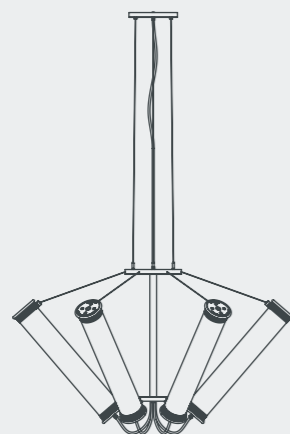

ITT SOLAR 6-700

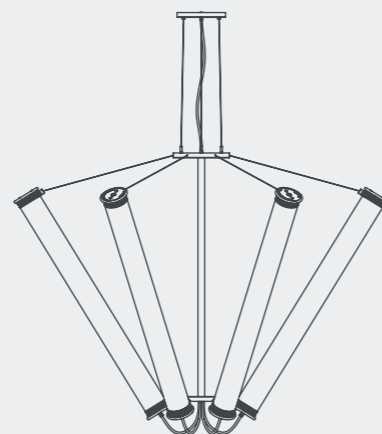

ITT SOLAR 6-1300

# IN THE TUBE™

de Dominique Perrault & Gaëlle Lauriot-Prévost



Dominique Perrault et Gaëlle Lauriot-Prévost

**IN** Dominique  
Perrault  
& Gaëlle  
Lauriot-Prévost

**THE  
TUBE™**

IP64 - INDOOR & OUTDOOR

#### DE L'ARCHITECTURE VERS LE DOMESTIQUE

L'architecte **Dominique Perrault** et la designer **Gaëlle Lauriot-Prévost** ont dessiné cette collection de luminaires à ce jour inédite, originale, presque incassable, inclassable, intemporelle et durable.

La collection "**IN THE TUBE**" est composée de modèles forts, figures libres et contraintes à la fois, déclinés en plusieurs versions de longueurs, diamètres et couleurs. Proposée en verre borosilicate, fermée de bouchons d'aluminium, capée de silicone, avec colliers de fixation en acier inoxydable, sous forme de suspensions, rampes, appliques, "**IN THE TUBE**" diffuse une lumière filtrée, adoucie, dirigée, orientée par le simple positionnement fixe ou amovible d'une maille-filtre façonnée ou d'un réflecteur, dont le matériau même "donne" la couleur. Acier inoxydable pour l'argenté, aluminium anodisé pour le cuivré et le doré.

"**IN THE TUBE**", collection de tubes méga-performants évoque des composants d'espionnage à la James Bond, ou des navettes à la Jules Verne.

#### FROM THE ARCHITECTURAL TO THE DOMESTIC

**English** • The architect **Dominique Perrault** and the designer **Gaëlle Lauriot-Prévost** designed this collection – which until now has never been produced – with the objective of it being utterly original, almost indescribable, nearly unbreakable, timeless and completely durable.

The "**IN THE TUBE**" collection comprises strong ideas, forms that are both free and constrained, and it comes in several lengths, diameters and colours. Made in borosilicate glass and closed with aluminium stoppers sealed in silicon, the mountings are in stainless-steel which allow it to be used as a suspension as well as on a wall or ceiling-mount. "**IN THE TUBE**" diffuses a soft, filtered light that can be oriented by the movable mesh filter or by a reflector whose colour determines the light given off: stainless steel for a silver light, anodised aluminium for copper or gold.

The "**IN THE TUBE**" collection of high-performance tubes could be just as easily at home in a James Bond spy kit as it could in a Jules Verne rocket.



#### VOM ARCHITEKTONISCHEN ZUM HÄUSLICHEN

**Deutsch** • Der Architekt **Dominique Perrault** und die Designerin **Gaëlle Lauriot-Prévost** haben diese vollkommen neuartige Beleuchtung entwickelt mit dem Ziel eine eigenständige, bisher nicht vorhandene Lichtquelle zu präsentieren, die überaus widerstandsfähig ist, eine eigene Gattung schafft und zeitlos ist.

"**IN THE TUBE**" vereinigt eine grosse Anzahl von Varianten in der Länge, im Durchmesser und mit dem Spiel der Farben.

Sie wird aus Borosilikatglas gefertigt, der Abschluss ist aus Aluminiumzapfen, die mit Silikon versiegelt sind. Die Aufhängevorrichtung ist aus Stahl und ermöglicht eine Befestigung an Decken, Wänden, etc.

"**IN THE TUBE**" verbreitet ein sanftes, gefiltertes Licht, das gerichtet werden kann durch den Reflektor oder das siebartige Netz, dessen Farbe das produzierte Licht bestimmt: Stahl für ein silbriges Licht, eloxiertes Aluminium für den Kupfer oder goldig.

Die "**IN THE TUBE**" – Kollektion könnte genauso Bestandteil eines James Bond-Sets sein oder einer Jules Verne-Rakete.

#### DALL'ARCHITETTURA AL DOMESTIC

**Italiano** • L'architetto **Dominique Perrault** ed il designer **Gaëlle Lauriot-Prévost** hanno realizzato questa collezione di luci a tutt'oggi inedita, originale, quasi infrangibile, non classificabile, atemporale e durevole.

La collezione "**IN THE TUBE**" consiste di modelli resistenti, forme che sono contemporaneamente libere e contenute, in varie lunghezze, diametri e colori. Prodotti in vetro borosilicato, chiusi da bocchettoni di alluminio, sigillati con del silicone, fissati da collari di acciaio inossidabile, in forma di sospensioni, rampe e montati sul soffitto o sulle pareti, "**IN THE TUBE**" dà una luce filtrata, addolcita, diretta, orientata mediante il semplice posizionamento fissato o amovibile di un filtro a rete oppure di un riflettore, il cui materiale stesso "dà" il colore. Acciaio inossidabile per una luce argentata, alluminio anodizzato per il ramato o dorato.

La collezione "**IN THE TUBE**" di tubi ad elevate prestazioni può ugualmente essere usata in scene di James Bond oppure in navette di Jules Verne.

#### DESDE LA ARQUITECTURA AL HOGAR

**Español** • El arquitecto **Dominique Perrault** y el diseñador **Gaëlle Lauriot-Prévost** han diseñado esta colección de luminarias de forma inédita, original, casi irrompible, inclassificable, atemporal y duradera.

La colección "**IN THE TUBE**" se compone de modelos fuertes, formas libres y limitadas a la vez, disponibles en varias versiones de longitud, diámetros y colores. Fabricada en vidrio de borosilicato, tapas de aluminio recubiertas de silicona y tornillos de acero inoxidable, que permite utilizarla como luminaria de suspensión, plafón de techo o aplique de pared, "**IN THE TUBE**" difunde una luz filtrada y suave, que puede orientarse con el filtro de malla extraíble o por el reflector que también determina el color de la luz. Acero inoxidable para la plata, aluminio adonizado para el cobre y el oro.

"**IN THE TUBE**" – Una colección de altas prestaciones que perfectamente podría utilizarse en la casa del agente secreto James Bond o en el cohete de Julio Verne.





*Left page*  
ITT 120-700  
SILVER-GOLD  
+ ITT HANG 2

*Right page*  
ITT 120-700  
SILVER-SILVER

*Pages 192-193*  
ITT 120-700  
SILVER-GOLD  
+ ITT HANG 2









Left page  
ITT 120-1300 GOLD-GOLD

Right page  
2 x ITT 120-700 GOLD-GOLD  
+ ITT HANG 2  
+ ITT CONNECTION BOX



3 x ITT 120-700 GOLD-GOLD



3 x ITT 100-500 GOLD-GOLD





COLLECTION | IN THE TUBE



Left page : 2 x ITT 100-350 SILVER-GOLD  
Right page : ITT 120-700 SILVER-GOLD + ITT HANG 2







*Left page*  
3 x ITT 100-500  
GOLD-SILVER

*Right page*  
2 x ITT 100-500  
SILVER-GOLD  
+ ITT  
CONNECTION  
BOX  
+ N° 302 BL  
COP-RAW







*Left page*  
5 x ITT 100-500  
GOLD-GOLD

*Right page*  
ITT SOLAR 6  
(6 x ITT 120-700  
GOLD-GOLD)





# IN THE TUBE ACCESSOIRES



**DIAG 1-100** (for ITT 350 & ITT 500)  
COLLIERS INCLINÉS | SLANTED COLLARS



**DIAG 1-120** (for ITT 700 & ITT 1300)  
COLLIERS INCLINÉS | SLANTED COLLARS



**HANG 1-120** (for ITT 700 & ITT 1300)  
SUSPENSION VERTICALE  
VERTICAL PENDANT



**HANG 2**  
SUSPENSION HORIZONTALE  
HORIZONTAL PENDANT

# IN THE TUBE ACCESSOIRES



**CONNECTION BOX**  
BOITIER DE CONNEXION  
**INDOOR AND OUTDOOR**

Cet accessoire de connexion peut également se placer derrière le tube  
This connection accessory could also be placed behind the tube



**COVER PLATE**  
PLAQUE D'ORNEMENT ACIER INOX  
ORNEMENTAL STAINLESS STEEL PLATE

Cet accessoire de connexion peut également se placer derrière le tube  
This connection accessory could also be placed behind the tube

# RÉFLECTEURS REFLECTORS



SILVER



GOLD

# MAILLES MESHES



SILVER



GOLD

## INFORMATION:

Il est possible de combiner les différentes finitions de réflecteurs avec les différentes finitions de mailles. Par exemple réflecteur Gold et mailles Silver.

Finishes of reflectors and meshes can be combined, for example reflector gold and meshes silver.



From left to center: ITT 100-350 + ITT 100-500 + ITT 120-700 + ITT 120-1300



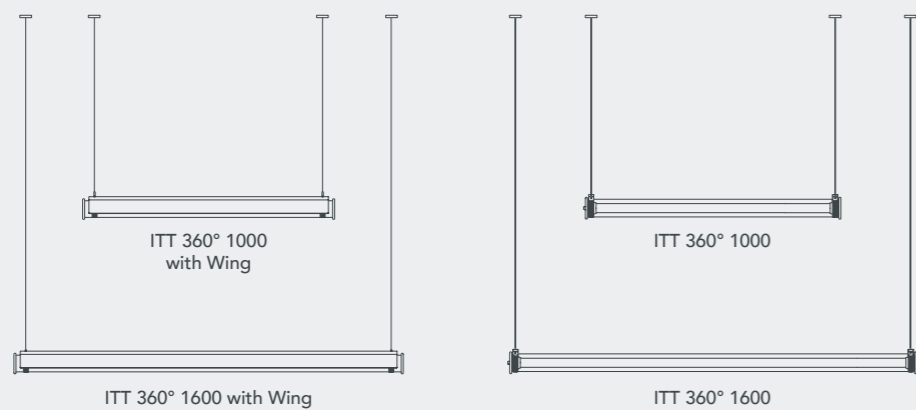
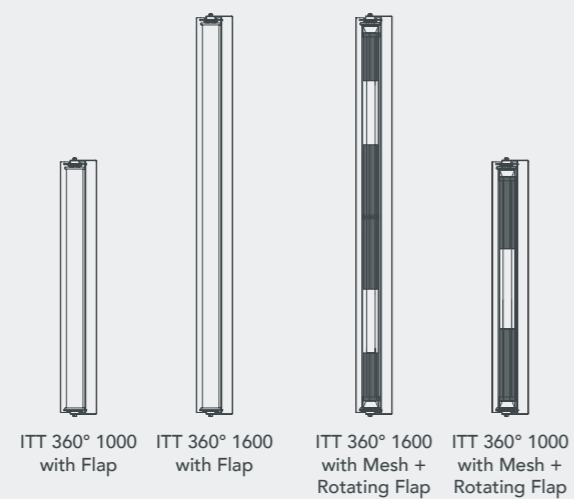
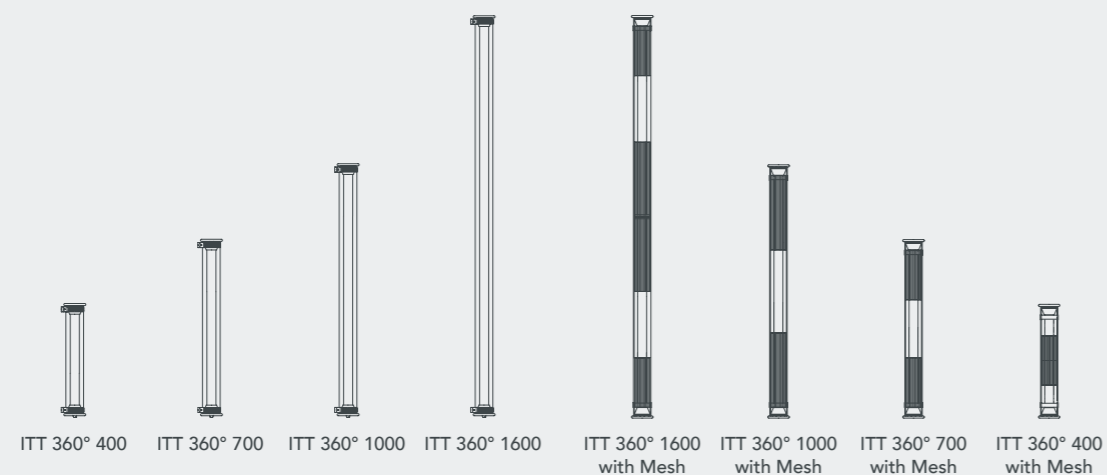

# IN THE TUBE™

de Dominique Perrault et Gaëlle Lauriot-Prévost

# 360°

# IN THE TUBE 360°™

IP65 -  
INDOOR &  
OUTDOOR

Dominique Perrault  
et Gaëlle Lauriot-  
Prévost

## IN THE TUBE 360° (ITT 360°)

La source de lumière (LED sur profilé d'aluminium) émet à 360° sur 100% de la longueur du tube.

Ces ITT 360° peuvent être montés:

- 1/ avec des mailles argentées ou dorées
- 2/ avec des volets, dits FLAPS permettant d'orienter la lumière, et pivotant à 360° (à l'horizontale ou à la verticale)
- 3/ avec le WING, conçu pour l'utilisation à l'horizontale

Applique ou suspension / Utilisation verticale ou horizontale.

Usage intérieur, extérieur, salle de bain / Câble de suspension et colliers fournis.

## IN THE TUBE 360° (ITT 360°)

**English** • The light source (LED on aluminium profile) renders 360° on 100% on the tube's length. ITT 360° could be used:

- 1/ without or with mesh silver or gold
- 2/ with FLAPS to orientate the light. Flaps pivotate 100° (horizontal and vertical)
- 3/ with WING for horizontal use

Wall or pendant / Horizontal or vertical use.

For indoor and outdoor use / Hang kit and collars supplied.

## IN THE TUBE 360° (ITT 360°)

**Deutsch** • Erstrahlt die Lichtquelle (LED auf einem Aluminiumprofil) rundum auf 360° und auf 100% der Länge des Rohres.

Diese ITT 360° können montiert werden:

- 1/ mit einer gold - oder silberfarbigen Masche
- 2/ mit 360° schwenkbaren Klappen, benannt FLAP, welche es ermöglichen, das Licht auszurichten
- 3/ die WNG ist konzipiert und geplant für die horizontale Benutzung

## IN THE TUBE 360° (ITT 360°)

**Italiano** • La sorgente luminosa (LED su profilo in alluminio) ha un'emissione a 360° sul 100% della lunghezza del tubo.

Questi ITT 360° possono essere montati:

- 1/ con maglie in argento o ottone
- 2/ con alette chiamate FLAP che consentono di orientare la luce e di ruotarla a 360° (in orizzontale o in verticale)
- 3/ Le WING (alette) sono progettate per un utilizzo orizzontale

## IN THE TUBE 360° (ITT 360°)

**Español** • La fuente de luz (LED sobre perfilado de aluminio) emite en 360° sobre el 100% de la longitud del tubo.

Los ITT 360° se pueden montar:

- 1/ con malla Silver o Latón
- 2/ con aletas (FLAPS) que permiten orientar la luz pivotando a 360° (en horizontal o vertical)
- 3/ con las WING que están ideadas para un uso en horizontal



ITT 360-1000 with BLACK WING  
without Mesh



ITT 360-1000 with BLACK FLAP ROTATING 360°  
with or without Mesh

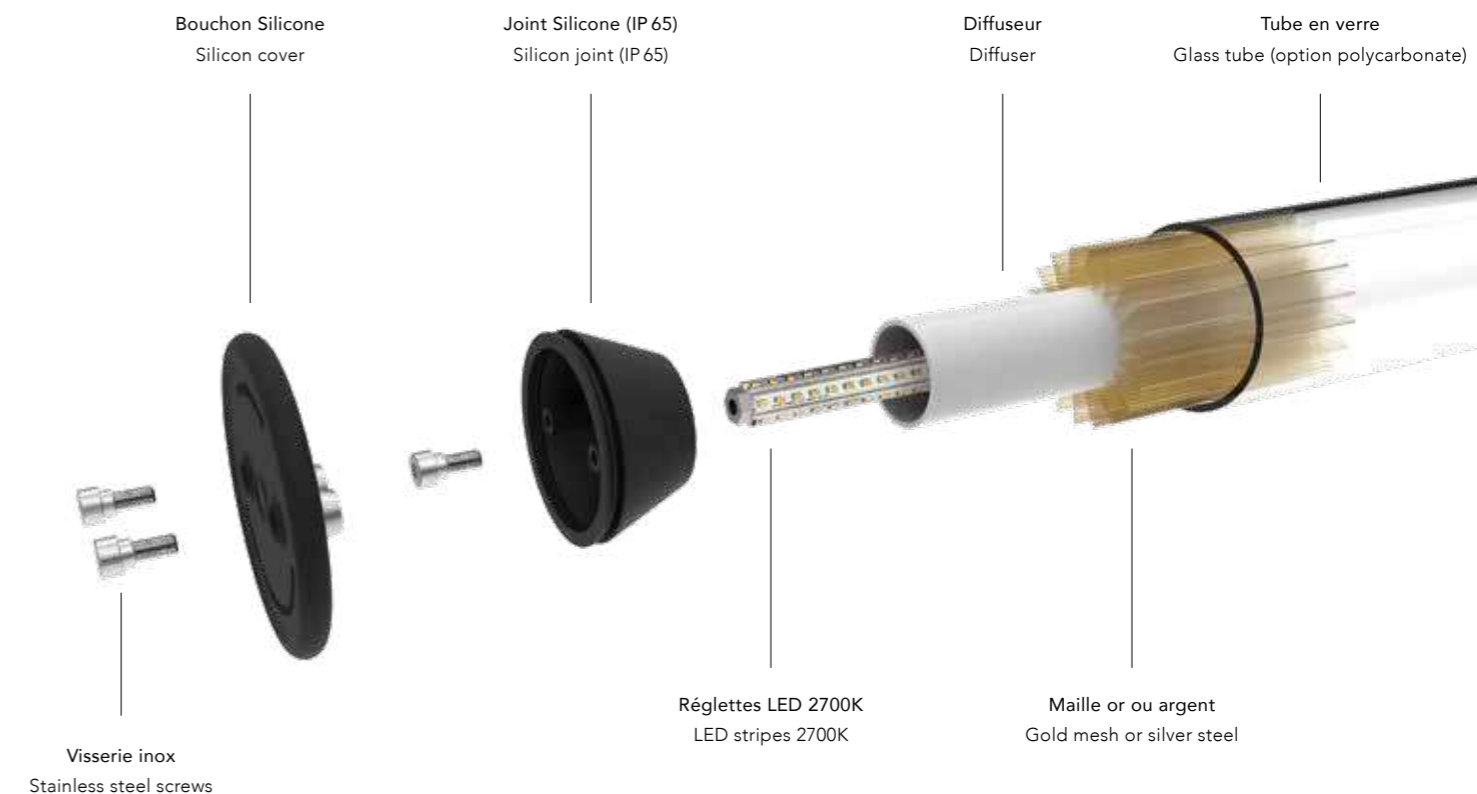







COLLECTION | ITT 360°

**ITT 360°**  
ACCESSOIRES  
ACCESSORIES

# ITT 360° WING & FLAP



*Pages 214 - 215*

ITT 360-1600  
GOLD (MESH)  
with BLACK  
WING

*Page 216*

ITT 360-700  
GOLD (MESH)  
with BLACK  
WING

*Page 217*

ITT 360-1000  
with BLACK FLAP  
ROTATING 360°







COLLECTION | ITT 360°



Left and right pages: ITT 360° - 1000 GOLD

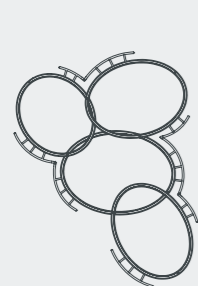

BROCHE M

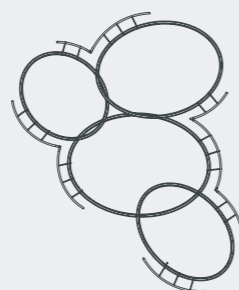
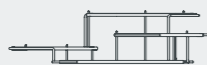

BROCHE L

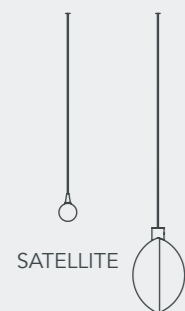
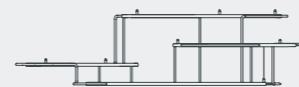

SATELLITE

LUNE

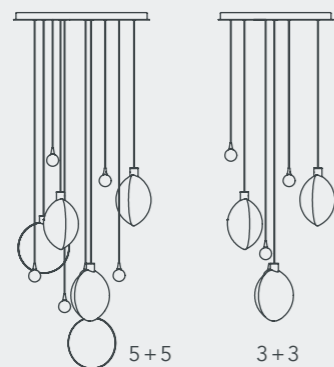

CANOPYS LUNES + SATELLITES



TRON

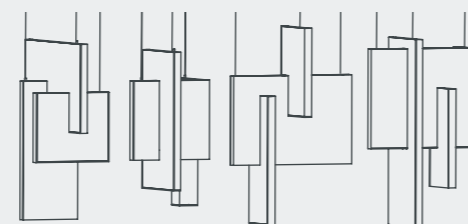

COMPOSITION  
TRON

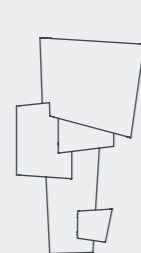

MAP 1

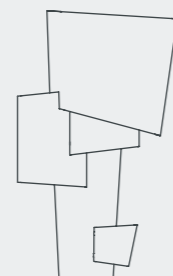

MAP 1 L

NEW

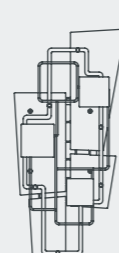

MAP 2

# COLLECTION

d'Éric de Dormael



# COLLECTION

d'Éric de Dormael

Admiratifs du travail d'**Éric de Dormael**, nous avons décidé de collaborer pour répondre à la demande d'œuvres uniques dans le cadre de prescription haut de gamme.

Mais nous éditons également dès cette année, quelques objets uniques par leur caractère. Ces "sculptures-lumière" caractérisées par leur légèreté, leur fluidité de forme et de transparence sont vouées aux jeux subtils de l'ombre et de la lumière. Les reflets, chatoiements, découpes et vibrations dansent sur les murs.

**Éric de Dormael** fait naître des images, des impressions, des sensations.

**English** • Long-time admirers of the work of **Éric de Dormael**, we were always delighted to work together on some special upscale projects.

But this year, we are also going to edit some of his work that we consider so unique and very special indeed.

These "sculpture lights", characterised by their fluidity, their ethereality, their form and their transparency, are all about the subtle interplay of light and shadow.

The reflections, shimmers, patterns and vibrations they create dance off the walls.

**Éric de Dormael's** creations bring forth images, they leave impressions and they provoke sensations.

**Deutsch** • Voller Bewunderung vor der Arbeit von **Éric de Dormael** und um einer Nachfrage nach hochwertigen Einzelstücken im Rahmen von Planungskonzeptionen nachzukommen, freuen wir uns über eine Zusammenarbeit mit ihm.

Darüber hinaus verlegen wir ab diesem Jahr einige seiner Objekte von außergewöhnlicher Eigenheit. Diese Leuchtskulpturen ausgezeichnet durch ihre Leichtigkeit, ihre fließenden Formen sowie ihre Transparenz sind durch ein feinsinniges Spiel aus Licht und Schatten bestimmt.

Wiederspiegelungen, Schimmer, Gestalten und Vibrationen tanzen auf den Wänden.

**Éric de Dormael** beschwört nicht nur Bilder, sondern auch Impressionen und Gefühle herauf.



BROCHE L

**Italiano** • Ammiratori del lavoro di **Éric de Dormael**, abbiamo inizialmente deciso di collaborare con lui per rispondere alla richiesta di opere uniche nell'ambito di progetti di alta gamma.

Ma a partire da quest'anno, pubblichiamo anche oggetti unici per le loro caratteristiche.

Queste "sculture di luce", caratterizzate dalla loro leggerezza, dalla fluidità della loro forma e dalla loro trasparenza, sono dedicate al sottile gioco di luci e ombre.

I riflessi, gli scintillii, i tagli e le vibrazioni danzano sui muri. **Éric de Dormael** dà vita a immagini, impressioni e sensazioni.

**Español** • Impresionados con la obra de **Éric de Dormael**, hemos decidido colaborar para responder a la demanda de obras exclusivas, en el contexto de prestaciones de gama alta.

Pero también editamos a partir de este año algunos objetos únicos por su carácter.

Estas "esculturas-lámparas" caracterizadas por su ligereza, su fluidez de forma y de transparencia están consagradas a los sutiles juegos de sombras y luces.

Reflejos, brillos, cortes y vibraciones bailan sobre las paredes.

**Éric de Dormael** da vida a imágenes, impresiones y sensaciones.



Composition  
with:  
4 x LUNES +  
4 x SATELLITES



BROCHE L + BROCHE M





Left page  
MAP 2

Right page  
MAP 1









COLLECTION D'ÉRIC DE DORMAEL

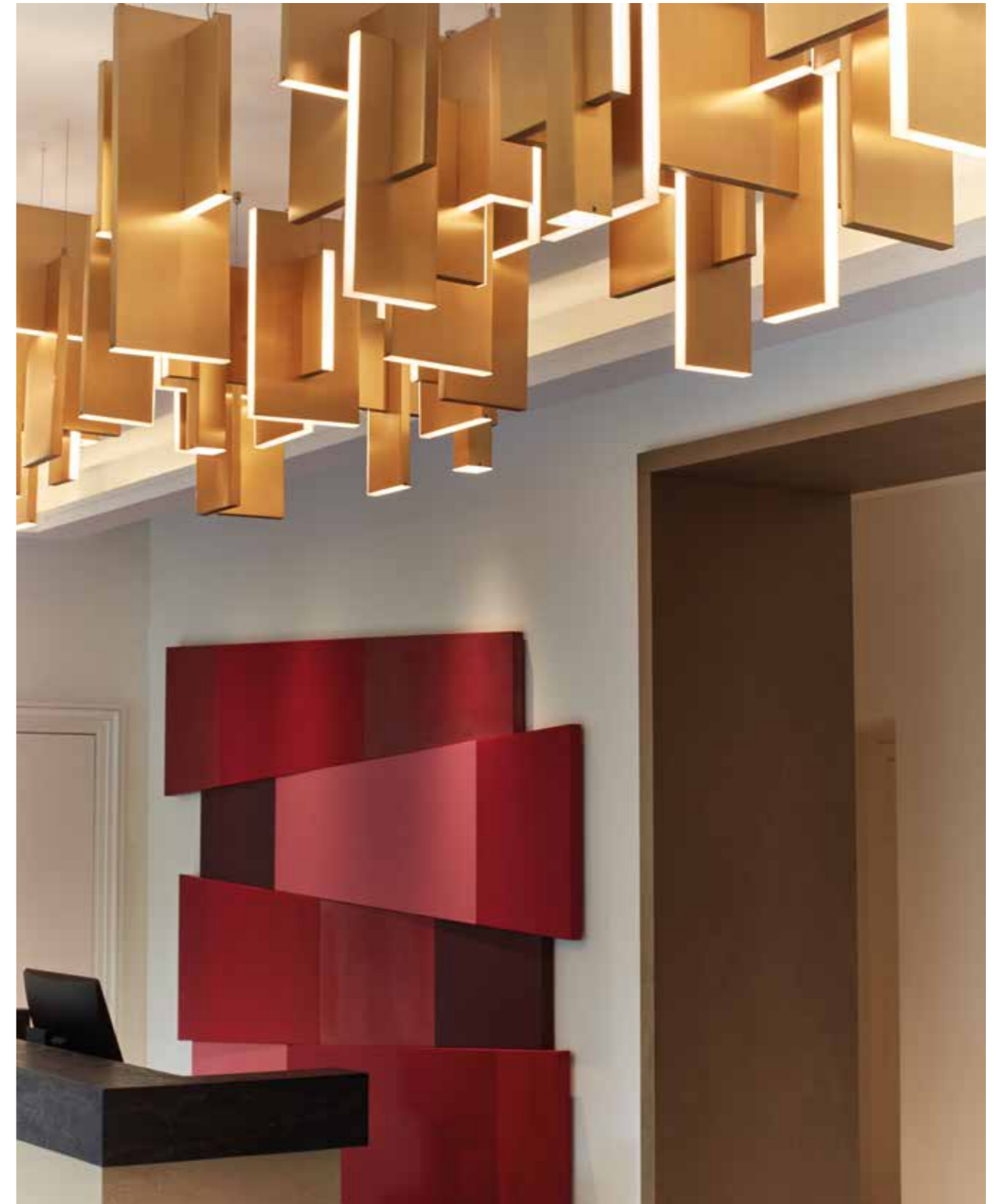

Left page : MAP 1

Right page : COMPOSITION TRON

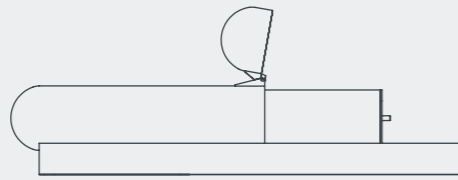

ISP TABLE LAMP

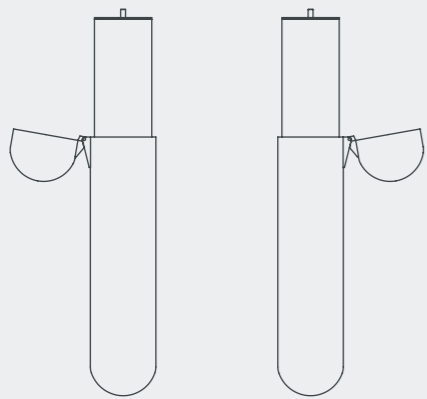

ISP WALL LAMP LEFT & RIGHT

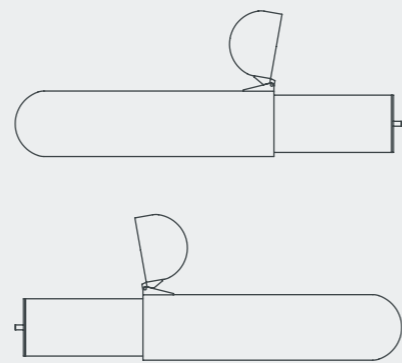

ISP WALL LAMP LEFT & RIGHT

**ISP**<sup>TM</sup>

d'Ilia Sergeevich Potemine



# ISP™

de Ilia Sergeevich Potemine

## PROJETÉE DANS LE TEMPS ET L'ESPACE

**Ceci n'est pas une lampe. C'est une lumière.**  
**Y voir le futur: il tient déjà dans la main.**

C'est tout le djinn de son inventeur. **Ilia Sergeevich Potemine** est russe. Mieux: italo-russe. Agent et accent double. On le croit designer. Il est pilote d'avion. Le ciel est son espace, le soleil un astre révolutionnaire, et la terre une escale temporelle, le temps de dessiner des luminaires fulgurants imaginés en pleine rupture mainstream. Rétro-référence: le temps d'un éclair, on pense à Howard Hugues. Potemine s'est déjà envolé. Ni dieu ni maître. Juste Achille Castiglioni, radical jusqu'à inventer les lumières de demain quand l'avenir et l'espace faisaient décoller la création vers le cosmos. Le génie de la lampe, c'était lui. Ilia Potemine, 30 ans tout juste, en est un nouveau. Sa lampe **ISP** en est le manifeste absolu et inclassable.

Encore une lampe. Oui, mais celle-ci ne ressemble à rien de connu. Conçue à contre-courant des artefacts formatés qui encombrant l'époque, la lampe de Potemine est un flambeau de haut vol qu'on imagine bâton de relais entre initiés et esprits éclairés. Évoquant à la fois un Nautilus, un HAL, une arche de la lumière, la lampe **ISP** est déjà une mythologie, un fiat-lux dépouillé à dessein du corpus lampesque orthodoxe.

Plus d'ampoule(s). Encore moins d'interrupteur. Mécanique, machinerie, contacts, LEDs: sa mise-

au-point technique aura mobilisé un ingénieur à plein-temps, dix-huit mois durant. Il y aura toujours un moteur sous un capot. Celui de la lampe **ISP** est un fuselage. L'aviation, toujours. S'intéresser à son contenu, c'est entrer dans une dimension inédite de la lumière. Une lumière-kryptonite qu'on extrait à main nue de sa gangue de laiton, qu'on pilote à 360°, et qu'on ré-encapsule quand elle ne sert plus.

Mise-à-feu, extinction des feux: jamais personne aura poussé la maîtrise de la lumière comme Potemine. En deux mouvements, le rêve de science-fiction devient une réalité palpable et quotidienne. Prise-en-main physique et mystique du geste: tel un silex du xxième siècle sur rampe de marbre, la lampe **ISP** se pose en véritable faisceau spatial.

Cent ans après le suprématisme de Malevitch, lui-même ex-dessinateur industriel pour les chemins de fer, **Ilia Sergeevich Potemine** invente une nouvelle avant-garde: le constructivISP. Ou le degré suprême de la pureté des objets. La dernière aventure moderne vient juste de commencer...

## English • LOST IN TIME AND SPACE

**This is not just a lamp. It is light itself.**  
**Look at the future: it's there in your hand.**

That is the genius of its inventor. **Ilia Sergeevich Potemine** is Russian. Better still, he's Italian-Russian: the original double agent. You may think he's a designer. In reality he's an airline pilot. The sky is his playground, the sun a revolutionary star and he has only dropped in on this earth for the time it takes for a quick layover. For the time it takes to design the extraordinary lights that are in complete contrast with what the mainstream is doing. Flashback: for a nanosecond Howard Hugues comes to mind. And Potemine has taken off again. No law, no order. Except perhaps Achille Castiglioni who was the original radical, inventing the lights of the future at a time when creativity was bound only by time and space. Ilia Potemine, just 30 years old, is in the same vein. His **ISP** lamp is rooted in the same manifesto and defies classification.

Another lamp. Yes. But this one is like no other that has come before. Designed in conscious opposition to the standard artefacts of our time, Potemine's lamp is more like a beautiful torch, like the baton passed between the runners in a race that counts only the enlightened and initiated among its participants.

Reminiscent of a Nautilus or a HAL, this ark for housing light comes with its own mythology, a minimalist interpretation of the injunction to "Let there be Light".

No more bulbs. Certainly no switches. Mechanics, machined, electrical contacts, LEDs: its technical aspects occupied an engineer full time for 18 months. Hoods are usually for hiding engines. The hood of the **ISP** is a fuselage. Back to airplanes. Investigating the interior is akin to entering a new dimension in lighting design. Like a piece of kryptonite-light you remove with your bare hands from its brass sheath, before revolving it a full 360° and then encapsulating it once again when it is no longer needed. Lighting. Extinguishing. None before Potemine has pushed lighting to such extremes. The simplest of movements and a science fiction dream becomes a palpable reality. The gesture takes on a physical and mystical reality: like a 21st Century flint sitting on a marble ramp the **ISP** lamp takes on the aura of a spatial beam.

100 years after Malevitch – himself a former industrial designer for the railways – **Ilia Sergeevich Potemine** has invented a new avant-garde: the constructivISP. The ultimate in design purity. The last modern adventure has just begun.

## Deutsch • IN RAUM UND ZEIT PROJIZIERT

**Dies ist keine Lampe. Es ist ein Licht.**  
**Die Zukunft darin sehen: Man hält sie bereits in Händen.**

Das ist die ganze Magie ihres Erfinders. **Ilia Sergeevich Potemine** ist Russe. Besser gesagt: Italo-Russe. Vermittler mit zweifachem Akzent. Man hält ihn für einen Designer. Er ist Pilot. Der Himmel ist sein Raum, die Sonne ein revolutionäres Gestirn, und die Erde ein zeitlicher Zwischenstopp, die Zeit, um phänomenale Lampen zu erschaffen, die überhaupt nichts mit dem Mainstream zu tun

haben. Retro-Referenz: Für einen kurzen Moment denkt man an Howard Hugues. Schon ist er uns entfallen. Weder Gott noch Meister. Allein Achille Castiglioni war so radikal, die Lampen von morgen zu erfinden, als Zukunft und Raum ließ er die Kreation in Richtung Kosmos gleiten. Er war das Genie der Lampe. Ilia Potemine, gerade erst 30 Jahre alt geworden, ist ein neues Genie. Seine **ISP**-Lampe ist ein absoluter und nicht klassifizierbarer Beleg dafür.

Eine weitere Lampe. Ja, aber diese ist anders als alles, was bisher bekannt ist. Entwickelt gegen den Strom der formatierten Artefakte, welche zurzeit in Überfluss bestehen, ist die Lampe von Potemine eine hochwertige Fackel, welche man sich als Verbindungsstück zwischen eingeweihten und aufgeklärten Geistern vorstellen kann. Sie lässt sowohl an einen Nautilus denken, einen HAL, einen Lichterbogen. Die **ISP**-Lampe ist bereits ein Mythos, ein "Es werde Licht", welches bewusst nichts von den orthodoxen Lampenkörpern behalten hat.



Ilia Sergeevich Potemine

Keine Glühbirne(n) mehr. Und vor allem keine Schalter mehr. Mechanik, Maschinerie, Kontakte, LEDs: Ihre technische Entwicklung soll einen Ingenieur in Vollzeit, 18 Monate lang, beschäftigt haben. Es wird immer ein Motor unter einer Haube geben. Der von der **ISP**-Lampe ist ein Rumpf. Immer wieder die Fliegerei. Sich für deren Inhalt zu interessieren bedeutet, in eine bisher nicht dagewesene Dimension des Lichts einzutauchen. Ein Kryptonitlicht, das man mit bloßer Hand aus seinem Messinggehäuse extrahiert, welches man in 360 Grad steuert, und welches man neu inkapselt, wenn man es nicht mehr braucht.

Licht anschalten, Licht ausschalten: niemand hat jemals das Licht so gut beherrscht wie Potemine. In zwei Bewegungen wird der Traum von Science-Fiction greifbar und alltägliche Wirklichkeit. Physischer Zugriff und die Mystik der Geste: Wie ein Feuerstein des 20. Jahrhunderts auf einer Marmorrampe ruht die **ISP**-Lampe auf einem regelrechten räumlichen Strahlenbündel.

Hundert Jahre nach dem Suprematismus von Malewitsch, selbst ein ehemaliger Industriedesigner für Eisenbahnen, erfindet **Ilia Sergeevich Potemine** eine neue Avantgarde: die constructivISP. Oder den höchsten Reinheitsgrad von Objekten. Das letzte moderne Abenteuer hat gerade erst begonnen...

#### Italiano •

### PROIETTATA NEL TEMPO E NELLO SPAZIO

**Questa non è una lampada. È una luce.  
Vi si vede il futuro: lo tiene già in mano.**

Questo è tutto il jinn del suo inventore. **Ilia Sergeevich Potemine** è russo. Meglio: italo-russo. Doppio agente e accento. È considerato un designer. È un pilota d'aerei. Il cielo è il suo spazio, il sole un astro rivoluzionario, e la terra una fermata temporanea, il tempo di disegnare luci sfolgoranti immaginate in piena rottura mainstream. Riferimento al passato: la durata di un lampo, si pensi a Howard Hugues. Potemine se n'è già andato. Né Dio né maestro. Soltanto Achille Castiglioni, radicale fino al punto di inventare le luci di domani quando il futuro e lo spazio facevano decollare la creazione verso il cosmo. Il genio della lampada,

era lui. **Ilia Potemine**, trent'anni soltanto, è il nuovo genio. La sua lampada **ISP** ne rappresenta il manifesto assoluto e inclassificabile.

Ancora una lampada. Sì, ma questa non somiglia a nulla di conosciuto. Concepita controcorrente rispetto ai manufatti formattati che ingombrano quest'epoca, la lampada di Potemine è una torcia che immaginiamo come un'ideale staffetta tra iniziati e spiriti illuminati. Evocando a volte un Nautilus, a volte un HAL, a volte un arco di luce, la lampada **ISP** è già diventata mito, un fiat-lux volutamente spogliato del corpo di lampada previsto dall'ortodossia.

Più nessuna lampadina(e). Ancor meno interruttori. Meccanica, macchinari, contatti, LED: la tecnica necessaria alla sua messa a punto ha richiesto un ingegnere a tempo pieno, per diciotto mesi. Ci sarà sempre un motore sotto un cofano. Quella della lampada **ISP** è una fusoliera. L'aviazione, sempre. Interessarsi al suo contenuto, significa entrare in una dimensione inedita della luce. Una luce-kryptonite che si estrae a mani nude dalla sua ganga di rame, che si pilota a 360°, e che torna a incapsularsi quando non serve più.

Messa a fuoco, spegnimento delle luci: nessuno mai ha padroneggiato le luci come Potemine. In due movimenti, il sogno della fantascienza diventa realtà palpabile e quotidiana. Gesto fisico e mistica del gesto: come una selce del XX secolo su un corrimano di marmo, la lampada **ISP** si pone in un vero fascio spaziale.

Cento anni dopo il Suprematismo di Malevitch, egli stesso un ex designer industriale per le ferrovie, **Ilia Sergeevich Potemine** inventa una nuova avanguardia: il costruttivISP. O il supremo grado di purezza degli oggetti. L'ultima avventura moderna è appena iniziata...

#### Español •

### PROYECTADA EN EL TIEMPO Y EL ESPACIO

**Esto no es una lámpara. Es una luz.  
Vea en ella el futuro: ya lo tiene en la mano.**

Toda ella es el genio de su inventor. **Ilia Sergeevich Potemine** es ruso. Mejor dicho: italorruso.

Agente y acento doble. Se cree que es diseñador. Es piloto de avión. El cielo es su espacio, el sol un astro revolucionario y la tierra una escala temporal, el momento de diseñar luminarias fulgurantes ideadas en plena ruptura con la corriente dominante. Referencia retro: en lo que tarda un relámpago, pensamos en Howard Hugues. Potemine ya ha echado el vuelo. Ni dios ni amo. Solo Achille Castiglioni, radical hasta inventar la iluminación del mañana, cuando las luces del futuro y el espacio hacían despegar la creación hacia el cosmos. El genio de la lámpara... era él. **Ilia Potemine**, 30 años recién cumplidos, es nuevo en esto. Su lámpara **ISP** es el manifesto absoluto e inclassificable.

Otra lámpara más. Sí, pero no se parece a nada conocido. Concebida a contracorriente de los artefactos formateados que saturan este tiempo, la lámpara de Potemine es una antorcha de altos vuelos que se imagina como relevo entre iniciados y espíritus iluminados. Evocando a la vez un Nautilus, un HAL, un arco de luz, la lámpara **ISP** ya es mitología, un "hágase la luz" despojado a propósito de su cuerpo lamparesco ortodoxo.

Basta de bombilla(s). Y menos aún de interruptores. Mecánica, maquinaria, contactos, ledes: su puesta a punto técnica habría movilizado a un ingeniero a tiempo completo, durante dieciocho meses. Siempre habrá un motor bajo un capó.

El de la lámpara **ISP** es un fuselaje. La aviación, siempre. El interés por su contenido es entrar en una nueva dimensión de la luz. Una luz criptonita que se extrae a mano desnuda de su caparazón de latón, que se pilota a 360° y que se vuelve a encapsular cuando ya no sirve. Encendido, extinción de luces: nunca nadie habrá

impulsado el dominio de la luz como Potemine. En dos movimientos, el sueño de la ciencia ficción se convierte en realidad palpable y cotidiana. La implicación física y mística del gesto: como un pedernal del siglo XXI sobre rampa de mármol, la lámpara **ISP** surge como auténtico haz espacial.

Cien años después del suprematismo de Malevich, él mismo antiguo diseñador industrial de ferrocarriles, **Ilia Sergeevich Potemine** inventa una nueva vanguardia: el constructivISP. O el más alto grado de la pureza de los objetos. La última aventura moderna acaba de empezar...







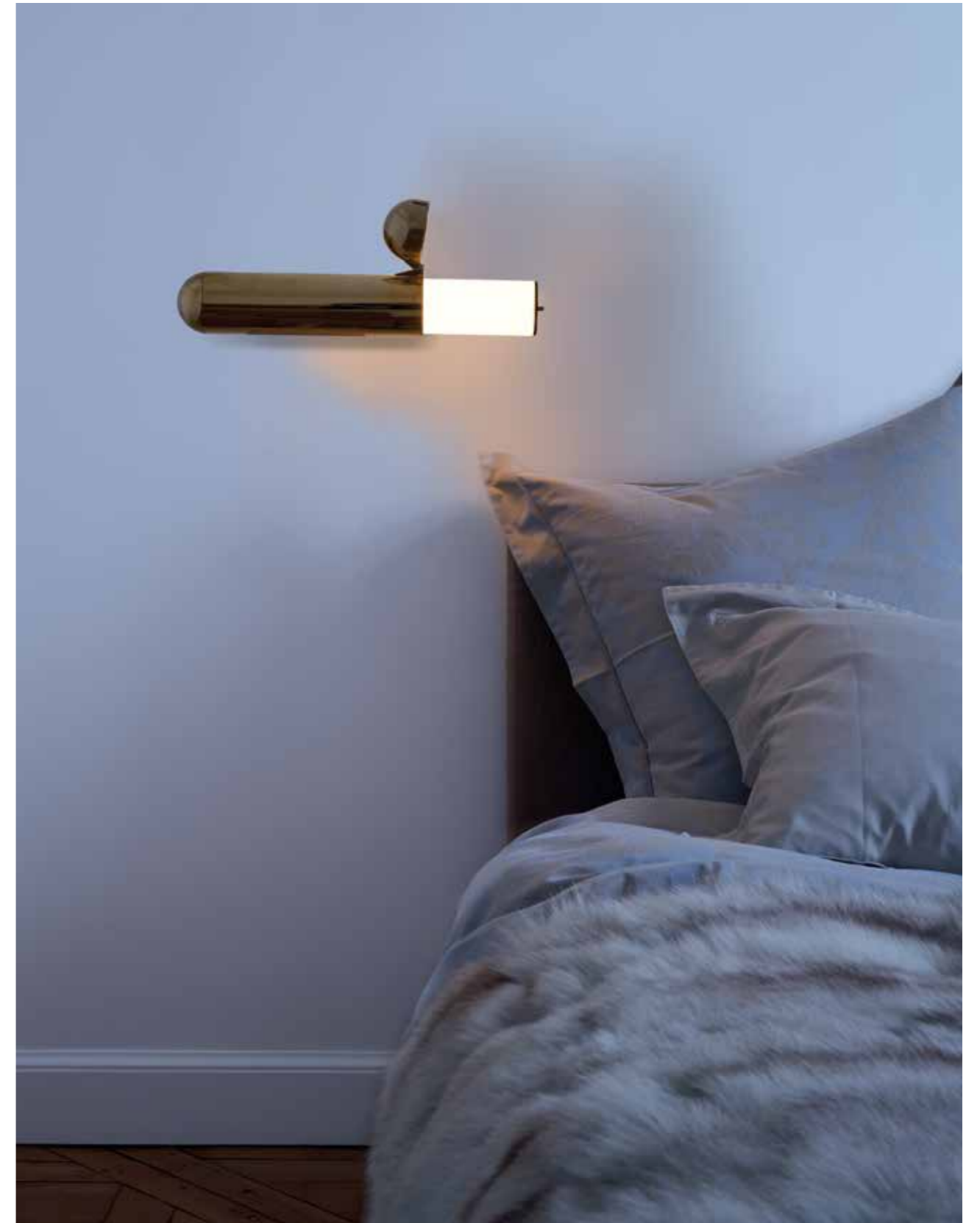

Left and right  
pages  
ISP WALL  
LAMP LEFT







Pages 242 - 244 : ISP TABLE LAMP WHITE MARBLE  
Page 245 : 2 x ISP TABLE LAMP BLACK MARBLE



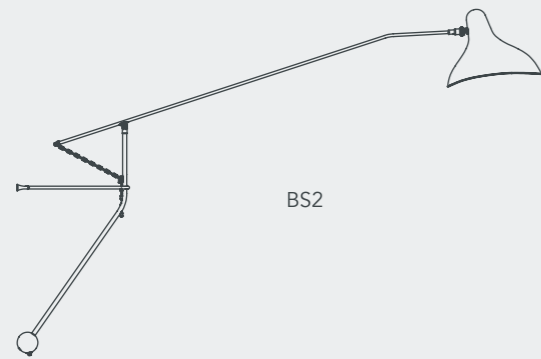

BS2



BS5

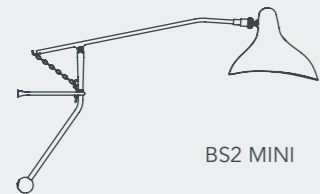

BS2 MINI



BS5 MINI

# MANTIS™

de Bernard Schottlander 1951

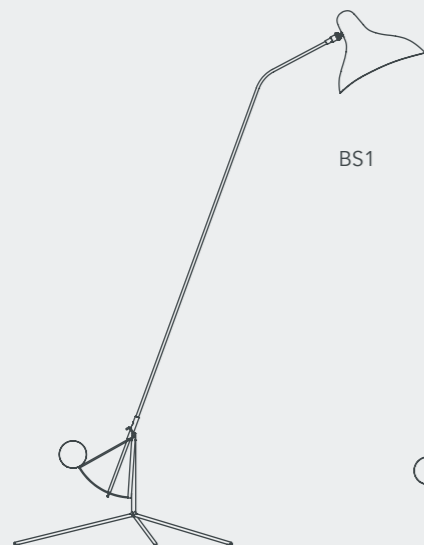

BS1

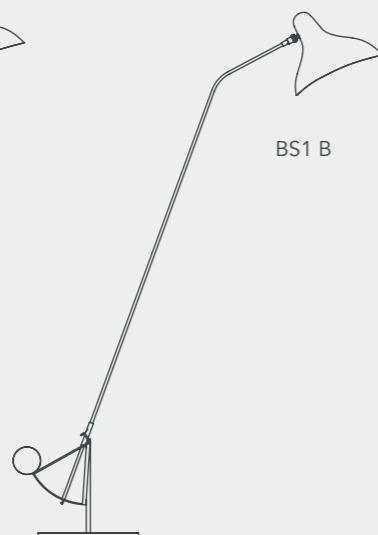

BS1 B



BS3

# MANTIS™ 1951

de Bernard Schottlander

## Historique

**1924**

Birth in Mainz

**1939**

Moves to England

**1951**

Creates the Mantis series of lamp

**1965**

Teaches metalwork at St Martins School of Art

**1966**

First solo show

Né en 1924 à Mainz en Allemagne, **Bernard Schottlander** arrive en Angleterre en 1939. Pendant la guerre, il travaille dans l'ingénierie structurale en tant que soudeur. Il prend alors des cours de sculpture au *Leeds College of Art*, puis grâce à une bourse du Anglo-French Art Centre à St John's Wood ; il étudie la sculpture pendant un an, à Londres. Sa formation de soudeur jouera un rôle considérable dans son œuvre.

**Bernard Schottlander** se définit comme designer pour l'intérieur, et sculpteur pour l'extérieur.

Il monte son atelier dans le nord de Londres aidé de son assistant George Nash. George Nash a une solide formation acquise dans les ateliers de l'armée de l'air britannique. La production de **Bernard Schottlander** s'apparente alors au travail d'artiste à la recherche de formes nouvelles, chaque pièce étant produite à la main et en série très limitée.

En 1963, il décide de se concentrer sur la sculpture uniquement, et à partir de 1965 il enseigne le travail du métal à St Martins School. Il expose cette même année avec le groupe Six Artists à l'*Institute of Contemporary Arts*, London. En 1966, il fait sa première exposition solo à l'*Hamilton Galleries* de Londres.

**English • Bernard Schottlander** was born in Mainz, Germany in 1924 and moved to England in 1939. After serving with the British Army in India, he learnt to weld and took a course in Sculpture at *Leeds College of Art* and subsequently – with the help of a bursary – at the *Anglo-French Art Centre* in St John's Wood.

**Bernard Schottlander** described himself as a designer for interiors and a sculptor for exteriors. After several successful years as an industrial designer, **Bernard Schottlander** chose to concentrate on sculpture. In the late 1950s he established a workshop in North London where he was ably assisted for many years by George Nash.

From 1965 he taught metalwork at St Martins School of Art. In the same year he was part of the group show Six Artists at the *Institute of Contemporary Arts* in London and in the following year (1966) had his first solo show at the *Hamilton Galleries*, London.

**Deutsch • Bernard Schottlander** wurde in Mainz, Deutschland im Jahre 1924 geboren und zog 1939 nach England. Nachdem in der britischen Armee in Indien diente, lernte er zu schweißen und nahm einen Kurs in der Bildhauerei am *Leeds College of Art* und anschließend – mit Hilfe eines Stipendiums – an der Anglo-Französisch Kunstzentrum in St. Johns Wood.

**Bernard Schottlander** beschrieb sich selbst als Designer für Innenräume und Bildhauer für Außen. Nach mehreren erfolgreichen Jahren als Industriedesigner, entschied sich **Bernard Schottlander**, auf Skulpturen zu konzentrieren. In den späten 1950er Jahren gründete er eine Werkstatt in North London, wo er geschickt für viele Jahre von George Nash unterstützt wurde.

Von 1965 lehrte er Metallarbeiten an der St. Martins School of Art. Im selben Jahr war er Teil der Gruppe Sechs Künstler am *Institute of Contemporary Arts* in London und im folgenden Jahr (1966) hatte er seine erste Einzelausstellung in der *Hamilton Galleries*, London.

**Italiano •** Nato nel 1924 a Mainz in Germania, **Bernard Schottlander** arriva in Inghilterra nel 1939. Durante la Guerra lavora in ingegneria strutturale in qualità di saldatore. Dopo di che egli segue dei corsi di scultura presso il *Leeds College of Art*, quindi grazie ad una borsa di studio dell'*Anglo-French Art Centre* di St. John's Wood ; per un anno studia scultura a Londra. Il suo tirocinio quale saldatore avrà un ruolo eccezionale per le sue opere.

**Bernard Schottlander** si definiva come designer di interni e scultore di esterni. Ha aperto il suo studio nel nord di Londra con l'aiuto del suo assistente, George Nash. George Nash possiede un solido tirocinio acquisito nei laboratorio dell'esercito dell'aeronautica britannica. La produzione di **Bernard Schottlander** è quindi associata al lavoro di artista nella ricerca di forme nuove, ed ogni pezzo era prodotto a mano ed in serie molto limitata.

Nel 1963, egli decide di concentrarsi unicamente nella scultura, ed a partire dal 1965 egli insegna la produzione di oggetti metallici presso la Scuola di St. Martin. Espone questo stesso anno con il gruppo "Six Artists" presso l'*Institute of Contemporary Arts* di Londra. Nel 1966 presenta la sua prima mostra da solo presso l'*Hamilton Galleries* di Londra.

**Español •** Nacido en 1924 en Mainz, Alemania, **Bernard Schottlander** llegó a Inglaterra en 1939. Durante la guerra, trabajó en ingeniería estructural como soldador. Posteriormente, tomó clases de escultura en el *Leeds College of Art* y luego, a través de una subvención del Centro de Arte anglo-francés Art Centre St John's Wood, estudió escultura durante un año en Londres.

Su formación de soldador jugará un papel importante en su obra.

**Bernard Schottlander** se define como diseñador para el interior, y el escultor para el exterior.

Estableció su estudio en Londres norte ayudado por su asistente George Nash. George Nash ganó una sólida formación en los talleres de la Fuerza Aérea Real Británica. La producción de **Bernard Schottlander** se vuelve semejante a la obra del artista en busca de nuevas formas, cada pieza es producida a mano en serie limitada.

En 1963 decide dedicarse solo a la escultura, y desde 1965 enseñó carpintería metálica en St. Martins School. Expuso ese mismo año con el grupo de Six Artists en el *Institute of Contemporary Arts*, London. En 1966, hace su primera exposición en solitario en The *Hamilton Galleries* de Londres.



Bernard Schottlander





# HOMMAGE À CALDER



Bernard Schottlander

## HOMAGE À CALDER

Grand admirateur d'Alexander Calder, Bernard Schottlander crée en 1951 une série de luminaires du nom de **MANTIS**.

Le mouvement est la source d'inspiration de tout le travail de Schottlander: artiste, ingénieur-bricoleur, il met au point un système de pivot-contrepois astucieux, et utilise des joncs de métal souples et résistants. Projeté en l'air comme un acrobate, le réflecteur en aluminium repoussé est novateur: l'œil

du sculpteur le taille en mouvement hélicoïdal: la symétrie tire l'asymétrie.

Ses luminaires, jouant sur la tension entre l'équilibre et le déséquilibre, dessinant les secrets du vide et du plein, tels des mobiles, semblent défier les lois de la pesanteur. La poésie de l'objet invite au rêve: l'élégance sur un fil...

## English • TRIBUTE TO CALDER

As admirer of Alexander Calder, in 1951 Schottlander created the "**MANTIS**" series of lamps.

Movement is intrinsic to all of Schottlander's work: an artist, an engineer and in no small measure a handyman, he devised a clever system of counterweights combined with a series of strong and flexible metal bars. The shade also is unique of its kind. Like an acrobat suspended in mid-air, it is made from aluminium using spinning and chasing techniques that are a part of the metalworker's inventory of skills, but to which he has brought his sculptor's eye to create a helical movement in which the symmetrical and the asymmetrical are in opposition.

## Deutsch • HOMMAGE AN CALDER

Als Bewunderer von Alexander Calders Arbeiten entwickelt Bernard Schottlander 1951 eine Serie von Leuchten mit dem Namen "**MANTIS**".

Bernard Schottlander kommt 1924 in Mainz in Deutschland zur Welt und emigriert 1939 nach England.

Während des Kriegs arbeitete er als Schweißer in einer Munitionsfabrik. Nach seinem Bildhauer-Studium am Leeds College of Art, eröffnet er sein

Atelier für Beleuchtung und Bildhauerei.

Bernard Schottlanders Arbeiten als Künstler beschäftigen sich in der Folge mit der Suche nach neuen Formen. Alle Arbeiten werden von Hand gefertigt und nur in limitierten Serien.

Ab 1963 konzentriert er sich auf die Bildhauerei, zudem unterrichtet er Metallbearbeitung an der St. Martins Schule.

Die Bewegung ist die Grundlage aller Lampen von Schottlander. Als Künstler, als Ingenieur und besonders als Handwerker entwickelt er ein raffiniertes System, mit dessen Hilfe die Leuchten drehbar sind und die Neigung des Arms durch Umstecken am Gegengewicht höhenverstellbar ist. Der Reflektorschirm aus Aluminium, in die Luft geworfen wie ein Akrobat, ist bemerkenswert. Seine geschwungenen Linien im Spannungsfeld zwischen Symmetrie und Asymmetrie – kombiniert mit einem graziösen Gestell – gibt der Leuchte eine schwerelose Anmut. Die Lampe ist in einem Spannungsfeld des Gleichgewichts, und ist das Zeugnis der besonderen Fähigkeiten eines Metallarbeiters. Sein Auge hat ein Objekt geschaffen, dessen Feinheit und Eleganz entzückt.

## Italiano • TRIBUTO A CALDER

Grande ammiratore di Alexander Calder, Bernard Schottlander crea nel 1951 una serie di lampade intitolata **MANTIS**.

Tutto il lavoro di Schottlander si ispira al movimento: artista, ingegnere-bricoleur, esso sviluppa un sistema di perno-contrappeso ingegnoso, usa trafilati di metallo flessibili e resistenti. Proiettato come un'acrobata in aria, il riflettore in alluminio tornito è innovativo: l'occhio dello scultore lo taglia in movimento elicoidale, tensione fra simmetria e asimmetria. Le

sue lampade, sul filo tra equilibrio e squilibrio, disegnando i segreti del vuoto et del pieno, come mobiles di Calder, sembrano sfidare le leggi della gravità. La poesia dell'oggetto invita al sogno; l'eleganza su un filo...

*As admirer of Alexander Calder, in 1951 Schottlander created the **MANTIS**™ series of lamps. Movement is intrinsic to all of Schottlander's work.*

## Español • HOMENAJE A CALDER

Gran admirador de Alexander Calder, Bernard Schottlander creó en 1951 una serie de lámparas llamada **MANTIS**.

El movimiento es la fuente de inspiración de toda la obra de Schottlander: artista, ingeniero-manitas, diseñó un ingenioso sistema de pivote-contrapeso combinado a tubos metálicos flexibles y resistentes. Como un acróbata proyectado en el aire, el reflector de aluminio repulsado es único en su categoría. Schottlander utilizó su talento de escultor para crear un movimiento helicoidal en el que la simetría y la asimetría entran en oposición. Las lámparas **MANTIS**, jugando con la tensión entre equilibrio y desequilibrio, dibujando los secretos del vacío et del lleno, al igual de los móviles de Calder, parecen desafiar las leyes de la gravedad. La poesía del objeto invita al sueño; la elegancia sobre un hilo...



Left and right pages : MANTIS BS1 BL-BL





MANTIS BS1 BL-BL



MANTIS BS5 BL-BL



MANTIS BS2 BL-BL





MANTIS BS3 BL BL



MANTIS BS1 BL-BL



COLLECTION | MANTIS



Left page  
MANTIS BS2  
BL-BL

Right page  
MANTIS BS2  
MINI BL-BL





Left and right pages : MANTIS BS2 BL-BL







MANTIS BS2 MINI BL-BL

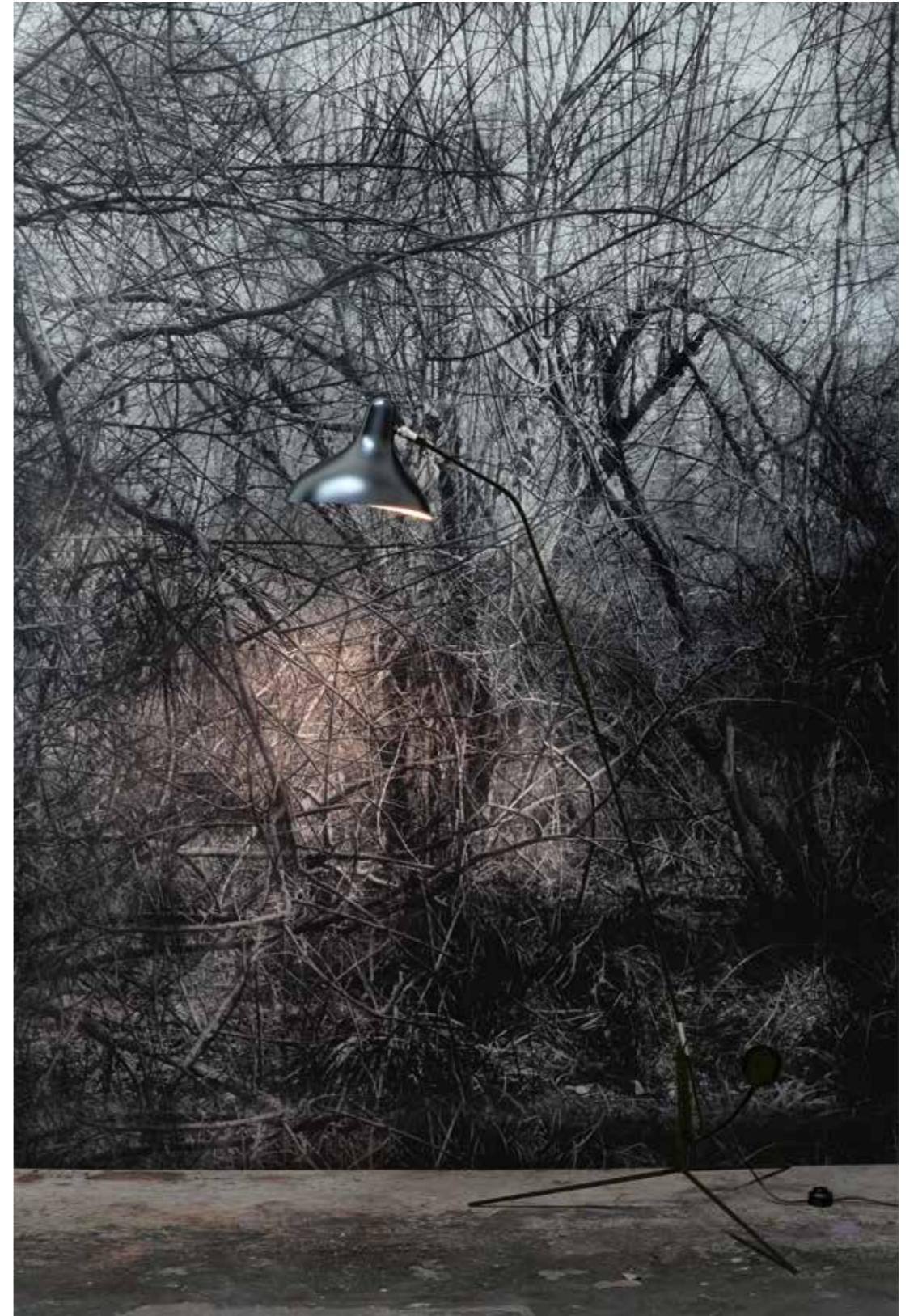

MANTIS BS1 BL BL





MANTIS BS5 & BS5 MINI | MANTIS BS5





Left page  
MANTIS BS1 B  
BL BL

Right page  
MANTIS  
BS5 MINI BL-BL  
BUILT-IN LED



> **PENDANT  
LAMPS**

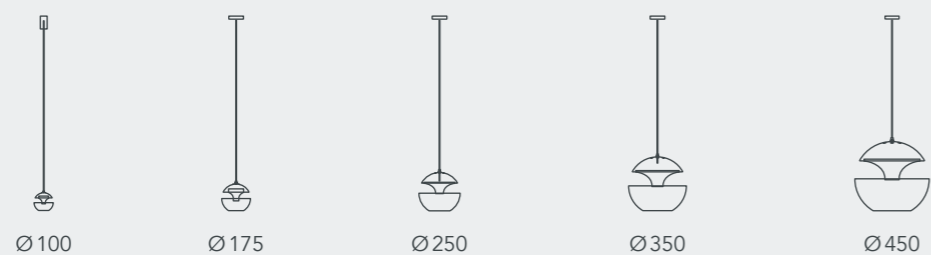

**CANOPYS HCS ALL SIZES**

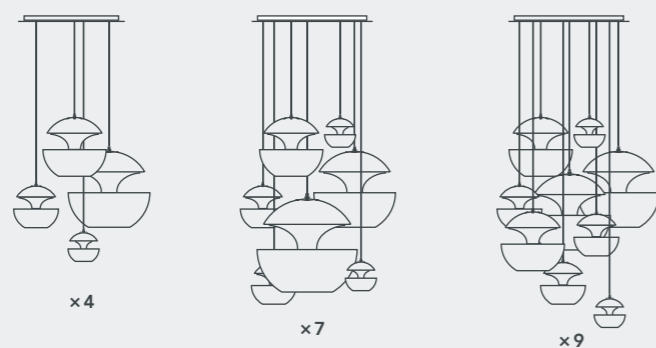

**CANOPYS FOR HCS MINI ONLY**

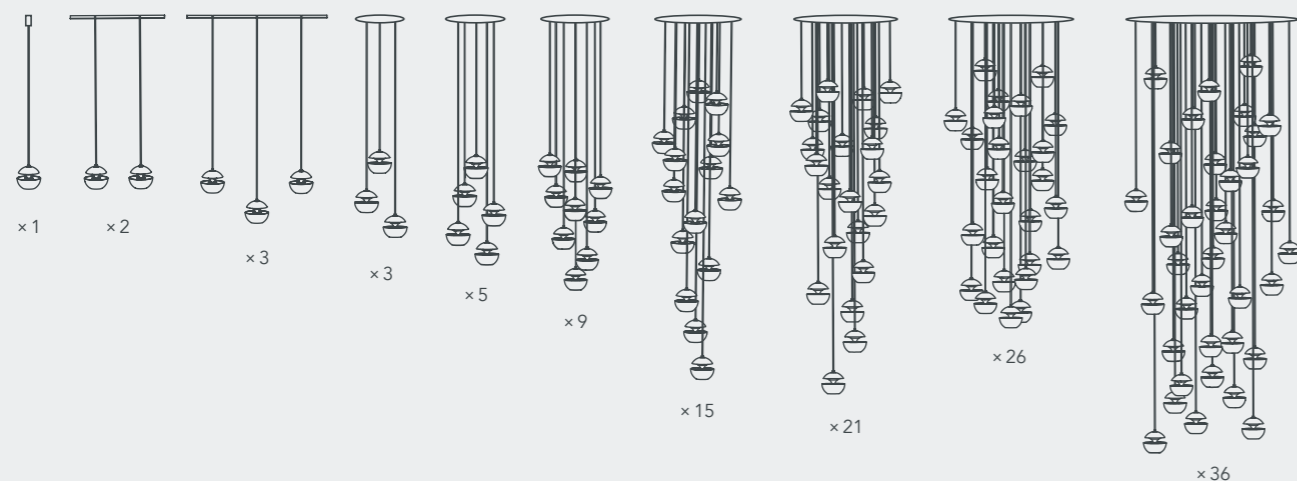

Bertrand Balas,  
dessiné par Tristan Balas,  
son petit fils

# HERE COMES THE SUN™

de Bertrand Balas

# HERE de Bertrand Balas COMES THE SUN™

**Bertrand Balas**, architecte de Toulouse né en 1935, aime contempler les couchers de soleil sur la Garonne.  
Comme il aime à le dire avec une certaine musicalité: " Cela me fait du bien ".

En août 1970, il crée le luminaire **Here Comes the Sun**.

À première vue, cette lampe originale ressemble à toutes les lampes dites elles aussi originales. Mais allumée, la suspension **Here Comes the Sun** est magique. La nuit devient douce, et rassurante.

Parallèlement, au printemps 1969, le groupe *The Beatles* du label Apple Records n'est pas en grande forme. Les tensions au sein du groupe sont fortes. Les relations sont glaciales.

George Harrison écrit alors *Here comes the sun*. Après l'hiver, le froid, la glace il est bon de sentir la chaleur des rayons du soleil.

Le titre sort en 1970 quelques jours avant la lampe de Bertrand Balas. à ce moment-là, Bertrand Balas décide alors de changer le nom de son luminaire de peur de se faire attaquer par les Beatles.

La chanson et le luminaire de Bertrand Balas auraient dû sortir de concert!

*Come together...*

**English • Bertrand Balas**, born in Toulouse in 1935 likes to watch the sun set over the Garonne river. With that musical lilt typical of the south, he likes to say: " It does me good ".

In August 1970 he designed the lamp **Here Comes the Sun**.

At first glance, this original design is like all the other lamps that get called an " original ". But once lit, the **Here Comes the Sun** hanging lamp takes on a magical quality. Darkness loses its rawness and metamorphoses into something reassuring.

At the same time as Balas was designing his lamp, in the Spring of 1969, *The Beatles* were having difficulties ; tension was running high and relations between the members distinctly frosty.

All of which prompted George Harrison to write *Here comes the sun*. After the cold and ice of the winter it is always good to feel the first rays of sunshine.

The song came out in 1970, just a few days before Bertrand Balas' lamp, prompting him to change the name, just in case *the Beatles* might take offence.

In fact, they could have taken the stage.

*Come Together...*



Bertrand Balas

**Deutsch • Bertrand Balas**, 1935 in Toulouse geboren, liebt den Sonnenuntergang über der Garonne. Mit dem im Süden typischen, musikalischen Tonfall pflegt er zu sagen: " Das tut mir gut ".

Im August 1970 entwarf er die Lampe **Here Comes the Sun**.

Auf den ersten Blick ist dieser Entwurf ebenso wie alle anderen Lampen, die " original " genannt werden.

Aber ein winziges Detail gibt der Hängeleuchte **Here Comes the Sun** eine poetische Note: die Nacht wird sanft.

In dieser Zeit, im Frühjahr 1969, waren die *Beatles* aus London nicht in Form. Die Spannung ist geladen und die Stimmung eisig. Diese Situation inspirierte George Harrison *Here comes the sun* zu schreiben. Nach einem kalten und eisigen Winter tut ein wärmender Lichtstrahl gut. Das Lied erscheint 1970 nur wenige Tage vor Bertrand Balas' Lampe. Er entscheidet sich, die Lampe anders zu benennen, um eine Auseinandersetzung mit den *Beatles* zu vermeiden. In der Tat: sie hätten die Bühne zusammen betreten sollen. *Come together...*

**Italiano • Bertrand Balas**, nato a Tolosa nel 1935, ama contemplare il sole che tramonta sulla Garonna. Con un tipico accento del Sud, l'architetto dice: " mi fa star bene ".

Nell'agosto del 1970 disegnò la lampada **Here comes the Sun**. A prima vista si potrebbe pensare che il suo design originale assomigli a quello di tutte le altre lampade altrettanto " originali ".

Ma, una volta accesa, la lampada a sospensione *Here comes the Sun* si illumina di qualcosa di magico. Il buio si dissocia dall'oscurità, diventando, al contrario, rassicurante.

Parallelemente, nella primavera del 1969, i *Beatles* vivevano un momento di crisi ; la tensione era alle stelle e i rapporti tra i membri del gruppo musicale incominciarono a rompersi.

Tutto ciò portò George Harrison a scrivere un nuovo pezzo intitolato *Here comes the sun*. Dopo il duro e freddo inverno è sempre piacevole avvertire il calore del primo raggio di sole.

Il brano uscì nel 1970, proprio alcuni giorni prima della lampada di Balas, spingendo l'architetto a cambiare il nome della sua lampada, per paura di una reazione da parte dei *Beatles*.

In realtà la canzone e la lampada avrebbero dovuto calcare il palcoscenico insieme...

*Come together...*



**Español • Bertrand Balas**, nace en Toulouse en 1935, le gusta ver la puesta de sol sobre el río Garonne. Como le gusta decir con una cierta musicalidad: " Esto me hace sentir bien " .

En agosto de 1970 crea la luminaria **Here Comes the Sun**.

A primera vista, esta lampara original es como todas las lamparas que se llaman " originales". Pero iluminada, la Luminaria de suspension **Here Comes de Sun** tiene una calidad magica. La noche se vuelve dulce y tranquilizadora.

Paralelamente, en la primavera del 1969, el grupo *The Beatles* y su marca *Apple Records* no estan en la mejor forma. Las tensiones en el seno del grupo son fuertes. Las relaciones son glaciares.

George Harrison escribio entonces *Here comes the sun*. Despues del invierno, el frio y el hielo es agradable sentir el calor de los rayos del sol.

El titulo aparece en 1970 algunos dias antes de la luminaria de Bertrand Balas. En ese momento,

Bertrand Balas decide entonces cambiar el nombre de su luminaria por temor a ser denunciado por *The Beatles*.

La cancion y la luminaria de Bertrand Balas deberian de haber ido juntas de concierto!  
*Come together...*

*Once lit, the*  
**HERE COMES THE SUN™**  
*hanging lamp takes on a magical quality. Darkness loses its rawness and metamorphoses into something reassuring.*



COLLECTION | **HERE COMES THE SUN**



**Ø 10 cm**  
**(3,937 inches)**

HCS MINI

# LES CANOPYS MINI HCS ONLY

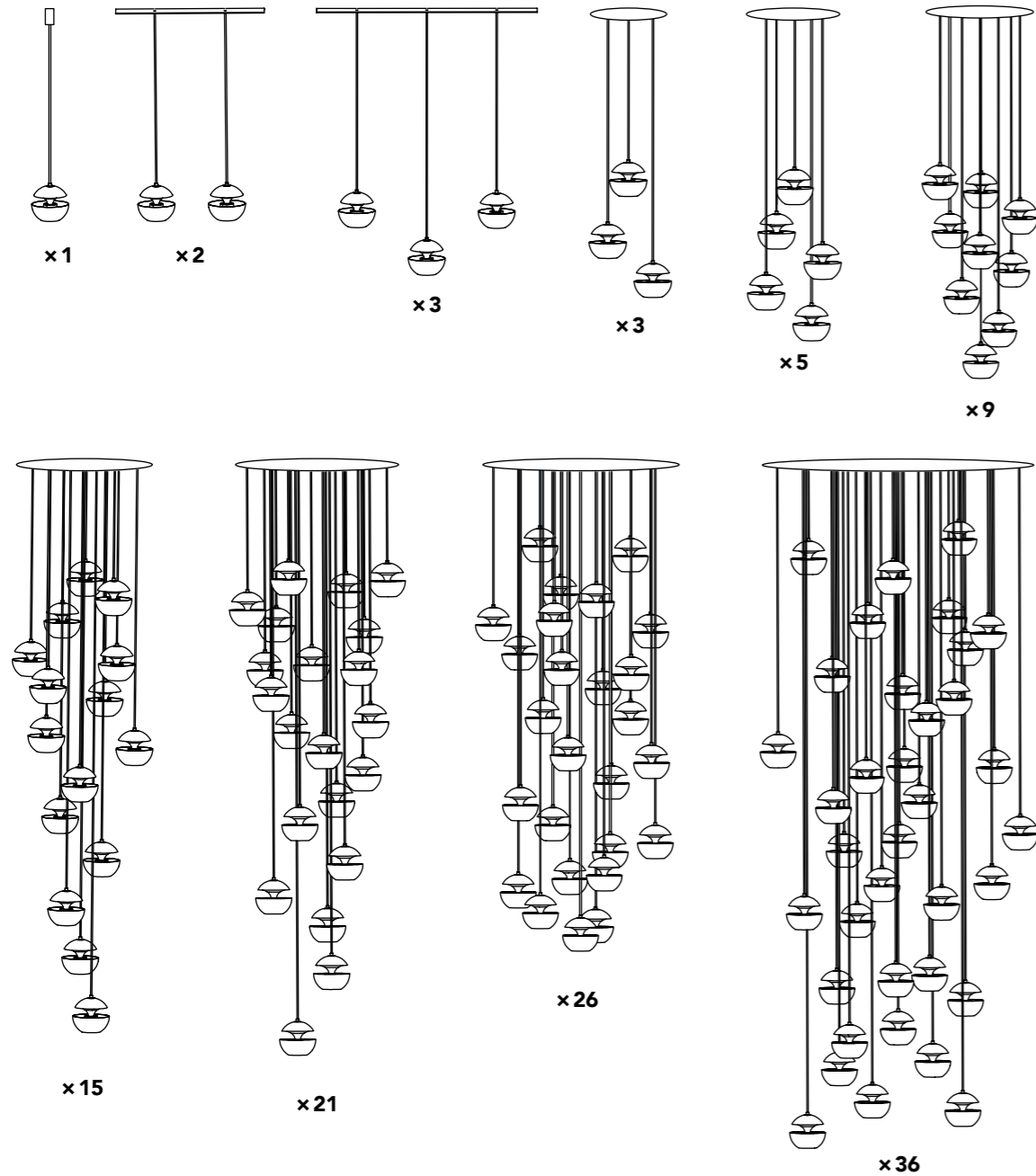

Ø 10 cm (3,937 inches)

# LES CANOPYS HCS ALL SIZES

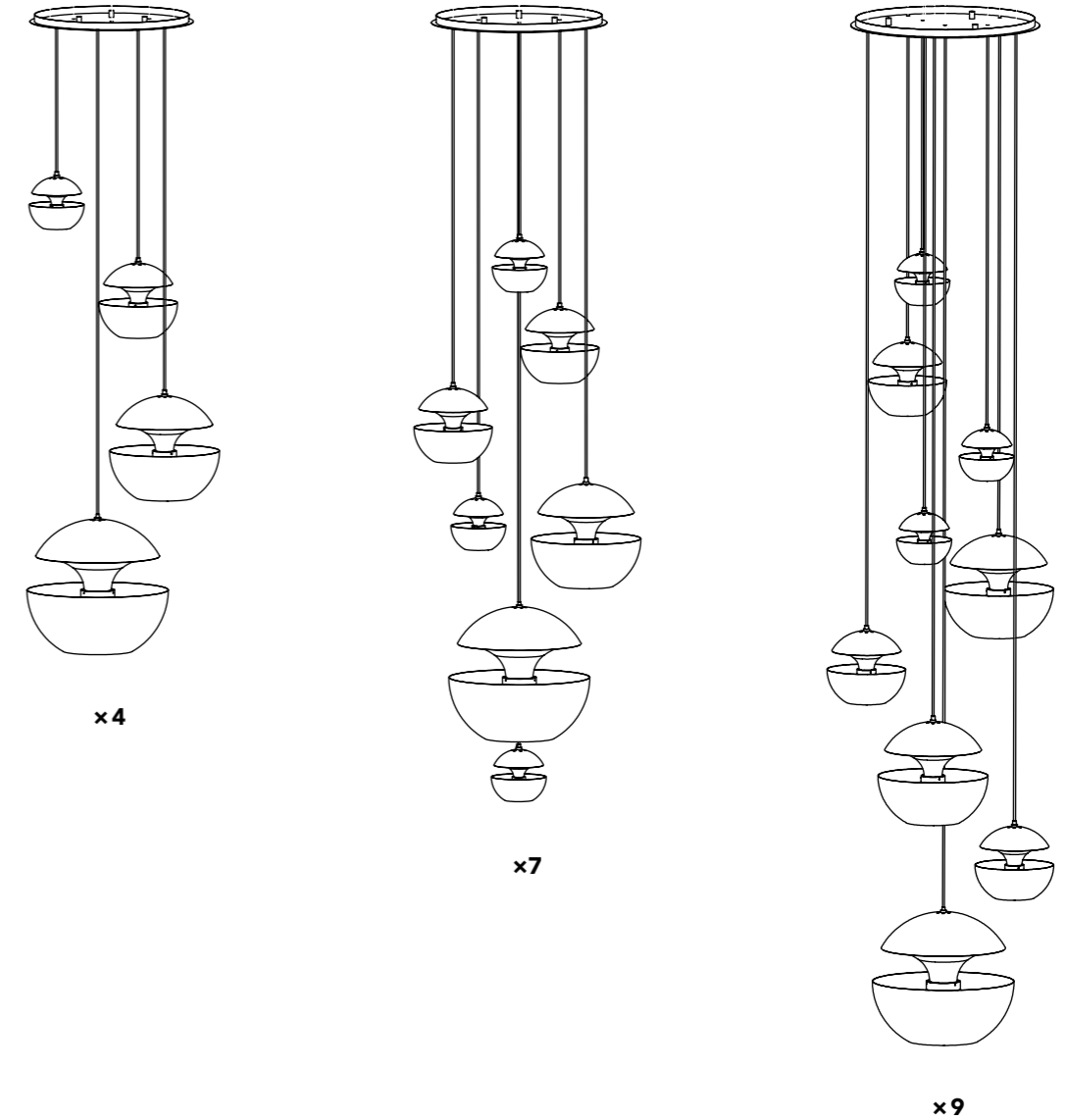

**ALL SIZES (mm)**  
**Ø 100 - 175 - 250 - 350 - 450**



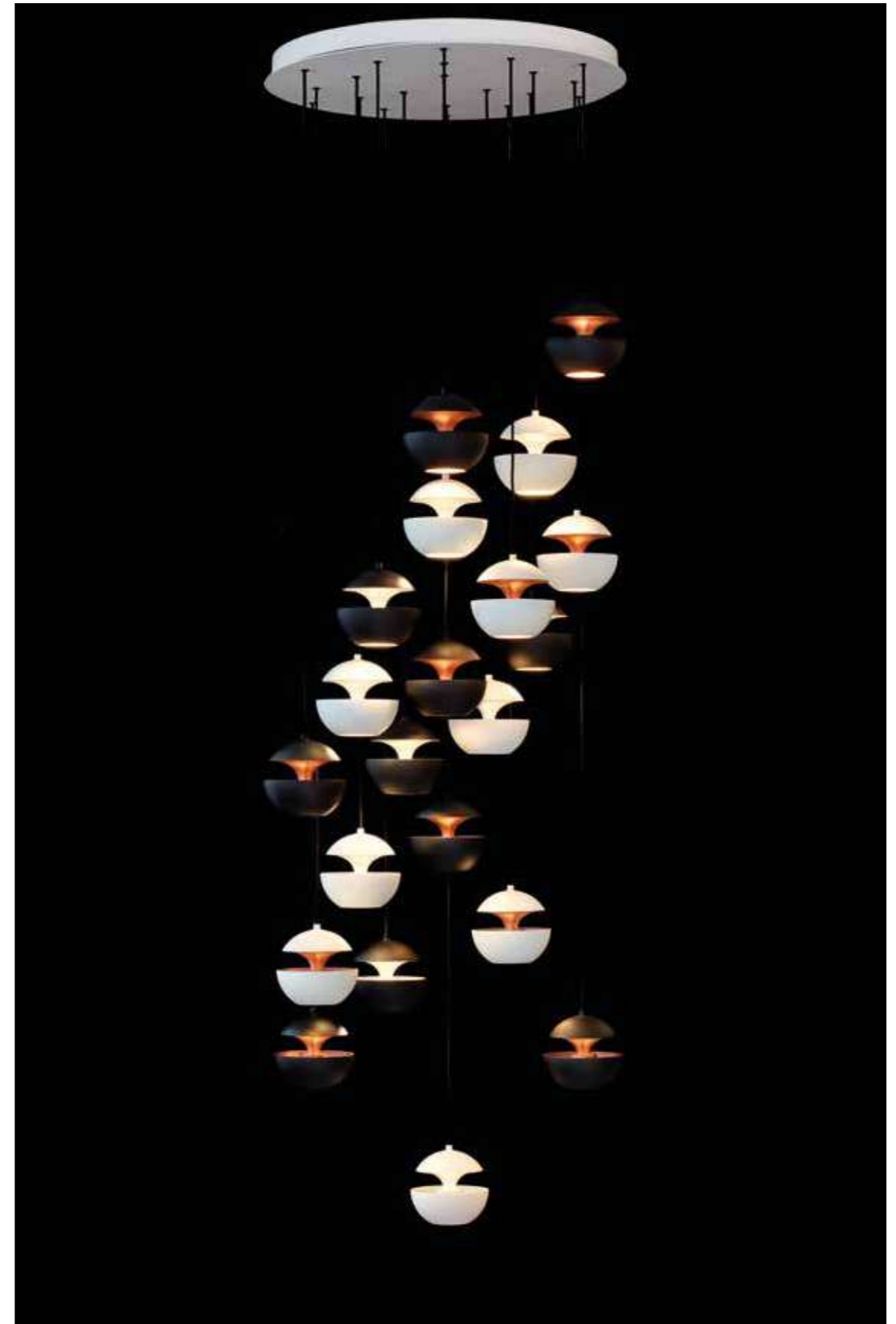

HCS MINI  
CANOPY

HCS MINI  
CANOPY x 21



Left page : 2 x HCS Ø 250 WH-COP  
Right page : HCS Ø 350 WH-COP







*Left page*  
HCS Ø 450  
BL-WH

*Right page*  
HCS Ø 450  
WH-WH

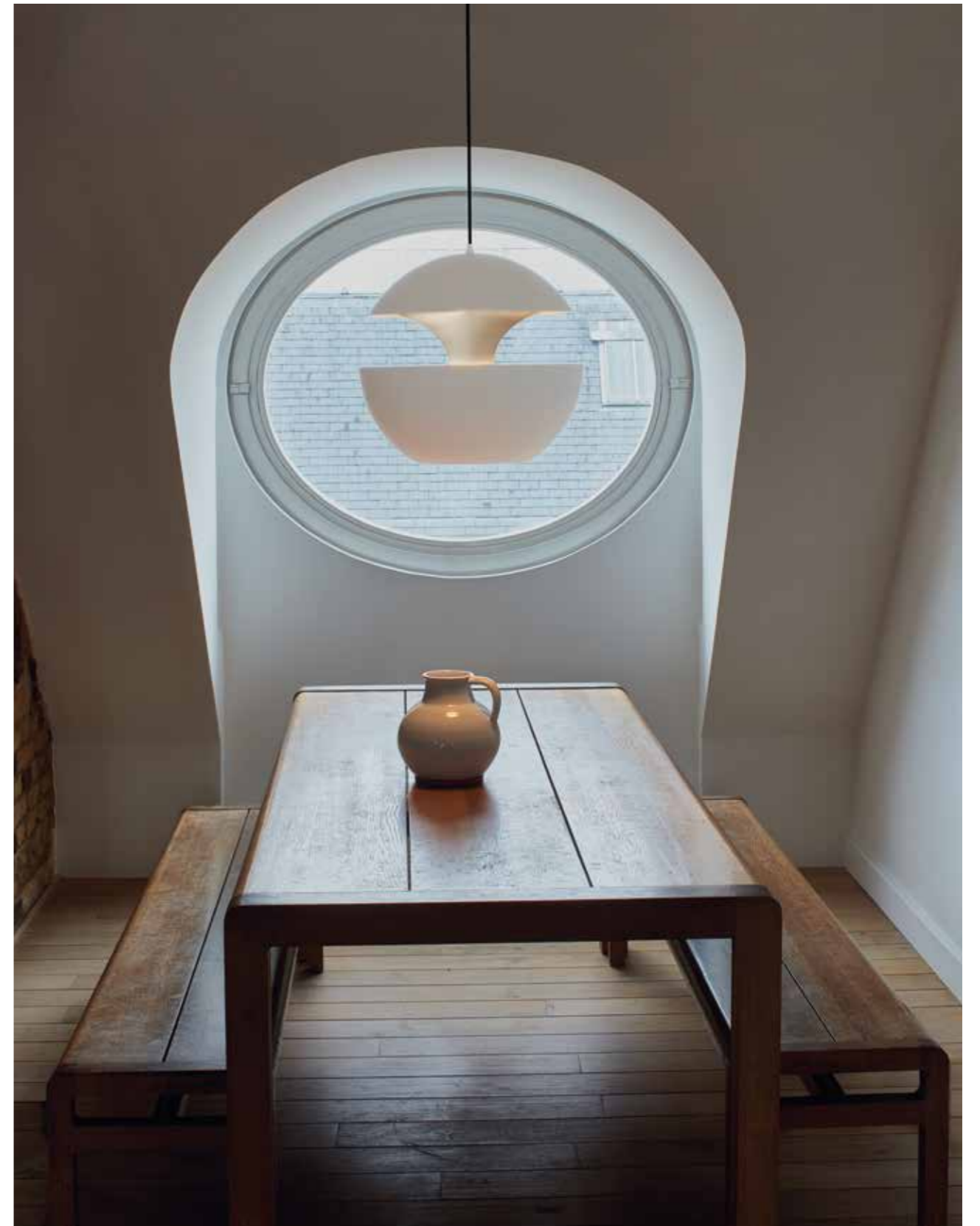



*Left page*

- HCS Ø 100
- + HCS Ø 175
- + HCS Ø 250
- + HCS Ø 350
- + HCS Ø 450

*Right page*

- HCS Ø 350
- BL-COP







Left page  
HCS Ø 350  
WH-COP

Right page  
HCS Ø 450  
WH-COP







Left page: HCS Ø450 BL-COP

Right page: HCS Ø250 WH-WH



Left page : HCS Ø350 WH-COP  
Right page : HCS Ø450 WH-COP







N° 322



N° 323

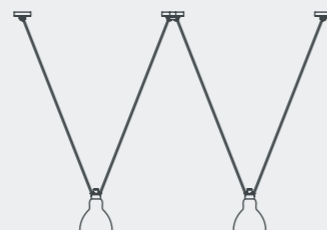

N° 324

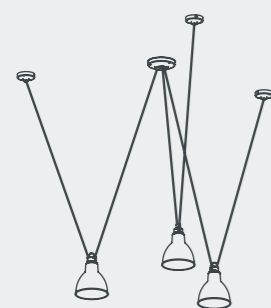

N° 325

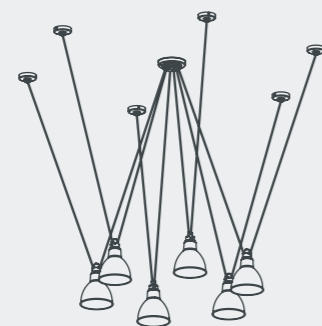

N° 326

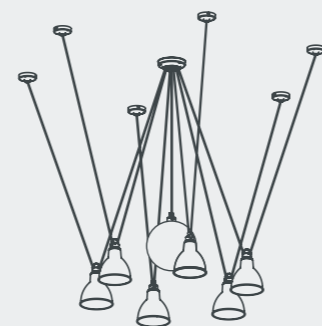

N° 327

# LES ACROBATES DE GRAS™

# LES ACROBATES DE GRAS™

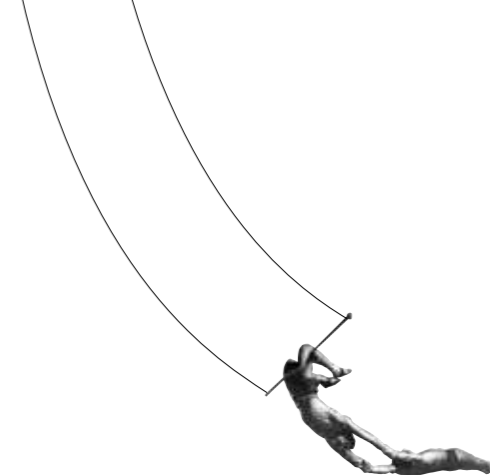

**Les Acrobates de GRAS** exécutent différentes figures dans les airs, perchés à plusieurs mètres de hauteur.

Les voltigeurs (N°323, N°324, N°325, N°326, N°327) exécutent l'acrobatie. Les diagonales donnent du dynamisme et de la gaieté au spectacle. Le porteur fiable et concentré (N°322) réceptionne les voltigeurs.

Le spectacle est fort: du mouvement, du rythme et de la couleur.

Les couleurs et les formes des réflecteurs de Gras et des boules de verre (**tailles L, XL, Ø 175 et Ø 250**) offrent un jeu dynamique et élégant.

**Les Acrobates de Gras** peuvent être reliés entre eux. Chacun peut monter son numéro!

Que le spectacle commence!

**English** • "Les Acrobates de GRAS" are adept at doing tricks high in the air, way above the ground. The high wire flyers (N°323, N°324, N°325, N°326, N°327) do the acrobatics, the diagonals adding dynamism and fun to the spectacle.

The catcher is concentrated and reliable (N°322) as it receives the flyers.

The spectacle is impressive, full of movement, rhythm and colour.

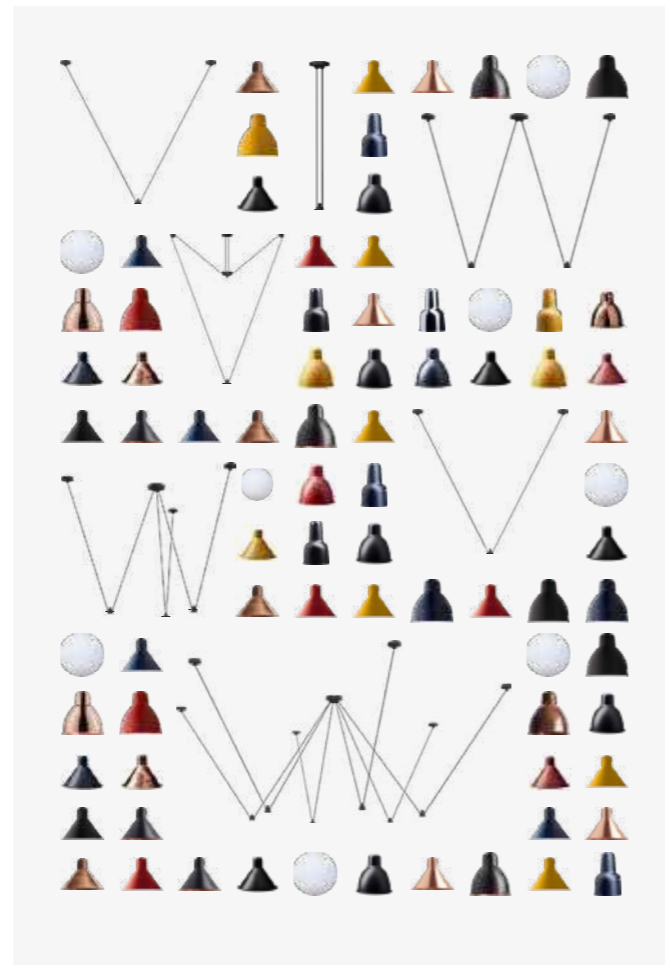

The colours and shapes of the Lampe Gras reflector and glass balls (**L, XL size & Ø175 & Ø250**) are elegant and sharp.

"Les Acrobates de GRAS" can be combined with each other.

Letting everyone make their own model.

Let the show begin!

**Deutsch** • "Les Acrobates de GRAS" (Die Akrobaten von GRAS) wirbeln gekonnt durch die Luft, weit weg vom sicheren Boden. Die Hochseil-Flieger (N°323, N°324, N°325, N°326, N°327) machen die Akrobatik, die Diagonalen tragen zusätzlich Dynamik und Spass zu diesem Schauspiel bei. Der Fänger (N°322) fängt konzentriert die Flieger.

Dieses Schauspiel beeindruckt mit seiner Bewegung, dem Rhythmus und den Farben.

Die eleganten Farben und Formen der Lampe Gras-Schirme und Glaskugeln (**L, XL-Größe, Ø175 und Ø250**) bringen die Spannung hervor.

"Les Acrobates de GRAS" sind miteinander kombinierbar. Jeder kann seine eigene Vorstellung gestalten!

Die Show kann beginnen!

**Italiano** • "Les Acrobates de GRAS" Gli acrobati di GRAS disegnano diverse figure nell'aria, sospesi

a diversi metri di altezza. I funamboli (N°323, N°324, N°325, N°326, N°327, N°328) fanno acrobazie. Le diagonali regalano dinamismo e allegria allo spettacolo. Il supporto (N°322), affidabile e concentrato, accoglie i funamboli. Lo spettacolo é d'effetto, movimento ritmo e colore.

Colori e forme dei riflettori di GRAS i sfere di vetro (**misure L e XL, Ø 175 & Ø 250**) regalano un gioco dinamico ed elegante.

Gli acrobati di GRAS possono essere collegati tra loro, ognuno può deciderne il numero.

Che lo spettacolo abbia inizio!

**Español** • "Les Acrobates de GRAS" ejecutan diferentes figuras en el aire, colgados a varios metros de altura. Los volteadores (N°323, N°324, N°325, N°326, N°327) ejecutan las acrobacias. Las diagonales dan el dinamismo y la alegría del espectáculo. El porteador, fiable y centrado (N°322), recibe los volteadores.

El espectáculo es fuerte: con movimiento, ritmo y color.

Los colores y las formas de los reflectores GRAS y las bolas de cristal (**tallas L y XL, Ø 175 y Ø 250**) ofrecen un juego dinámico y elegante. Los acróbatas GRAS se pueden interconectar.

Todo el mundo puede montar su número!

¡Que empiece el espectáculo!

Useful and easy to use  
the application on:  
**www.acrobatesbuilder.fr**  
will help you to find your combination



# LES ACROBATES ACCESSOIRES



## PART AC 1

### Matériaux | Materials

Fonte acier noir satiné  
Black satin steel cast

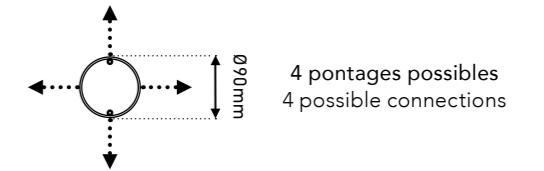

## PART AC 2

### Matériaux | Materials

Tube acier avec câble électrique - noir satiné  
Black satin steel tube with electric wire

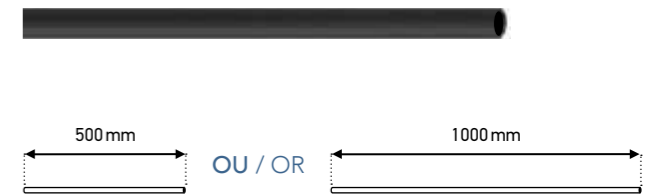

## PART AC 3

### Matériaux | Materials

Fonte acier noir satiné  
Black satin steel cast

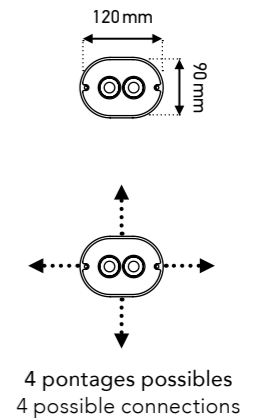

# 1 POINT ÉLECTRIQUE

## 1 ELECTRIC POINT

### 6 SUSPENSIONS

1 seul point électrique pour autant de combinaisons de jeux possibles (au plafond ou en mural!).

### COMBINAISONS MULTIPLES

Pontage à l'infini des Acrobates entre eux.

### INFINITÉ DE COMPOSITIONS

Hauteur – largeur – amplitude – géométrie – formes et couleurs d'abat-jour – combinaisons. Mais toujours avec la rigueur et l'élégance.

Pour jouer aux acrobates, suivez l'application Les Acrobates de GRAS sur [www.acrobatesbuilder.fr](http://www.acrobatesbuilder.fr)

### 6 HANGING LAMPS

A single electrical connection (either on the ceiling or the wall) creates a huge range of possibilities.

### MULTIPLE COMBINATIONS

Acrobates connected together, potentially ad infinitum in multiple combinations.

### INFINITE COMPOSITIONS

combinations of height, width, scale, geometry as well as the form and colour of the lampshades.

**But always with the same rigour and elegance.**

To become an acrobat, take a turn on the Les Acrobates de GRAS application on [www.acrobatesbuilder.fr](http://www.acrobatesbuilder.fr)

### 6 HÄNGELAMPEN

1 elektrischer Kontakt für eine grosse Anzahl von Kombinationen (sowohl an der Decke wie an der Mauer).

### MEHRFACHKOMBINATIONEN

Unendliche Verbindungsmöglichkeiten unter ihnen.

### UNENDLICHE

Kompositionsmöglichkeiten in der Höhe und der Breite - in der Weite - geometrisch - farblich und in der Form der Lampenschirme - grosse Wahlmöglichkeiten.

**Aber immer mit Präzision und Eleganz.**

Spielen Sie mit den Akrobaten und folgen Sie der Applikation Les Acrobates de GRAS auf [www.acrobatesbuilder.fr](http://www.acrobatesbuilder.fr)

### 6 SOSPENSIONI

Un solo alimentatore elettronico per tante combinazioni (al soffitto o da parete).

### COMBINAZIONI MULTIPLE

Un numero infinito di abbinamenti tra di loro.

### INFINITE POSSIBILITÀ DI COMBINAZIONI

Nell'altezza e nella larghezza - nella distesa - geometrico - cromatico e nelle forme di paralumi - grande scelta.

**Ma sempre con precisione ed eleganza.**

Giochi con gli Acrobati e segua l'applicazione Les acrobates de GRAS su [www.acrobatesbuilder.fr](http://www.acrobatesbuilder.fr)

### 6 LÁMPARAS COLGADAS

Un solo punto de corriente para múltiples posibilidades (para el techo o para el muro).

### MÚLTIPLES COMBINACIONES

Se puede hacer una asociación infinita entre acrobatas.

### INFINITAS MANERAS DE INSTALAR LA LÁMPARA

Se puede modificar su altura su amplitud su forma su color de pantalla. Lo más importante es que sepan que se puede hacer lo que quiera con la lámpara.

**Pero siempre con rigor y elegancia.**

Para jugar con los acróbatas pueden seguir la aventura bajando la aplicación las acróbatas de GRAS en [www.acrobatesbuilder.fr](http://www.acrobatesbuilder.fr)

PART AC 1



PART AC 2



PART AC 3



PART AC 2 PART AC 1

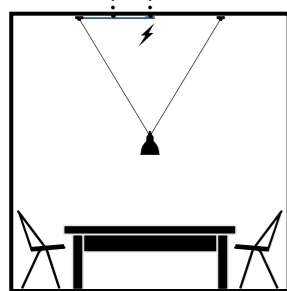

N° 323

PART AC 1 PART AC 2

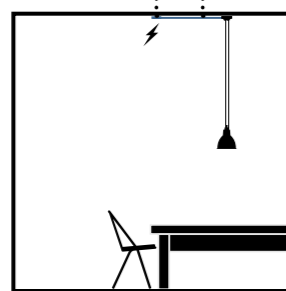

N° 322

PART AC 2 x 2

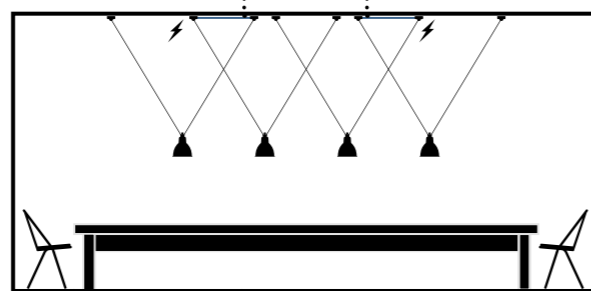

N° 323 x 4

PART AC 2

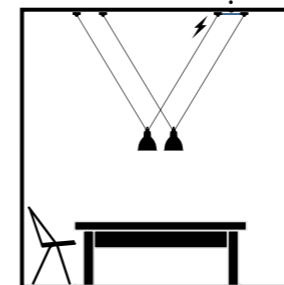

N° 323 x 2

PART AC 3

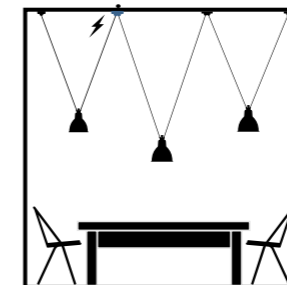

N° 323 + N° 324

PART AC 2 x 4

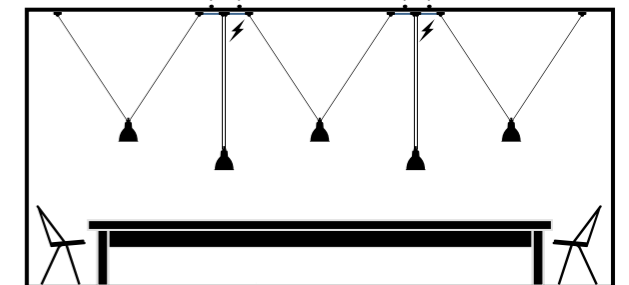

N° 323 x 3 + N° 322 x 2

PART AC 2

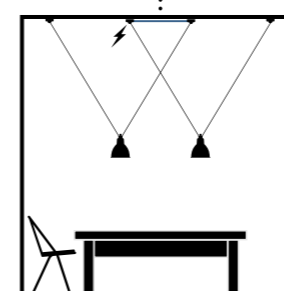

N° 323 x 2

PART AC 2 x 2

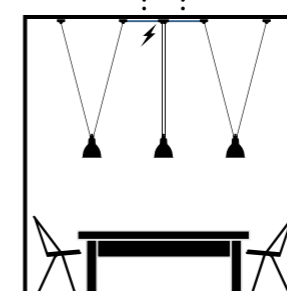

N° 323 x 2 + N° 322

PART AC 3

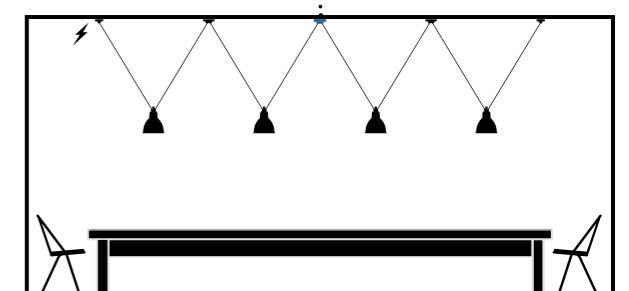

N° 324 x 2



# DÉPORTE REMOTE

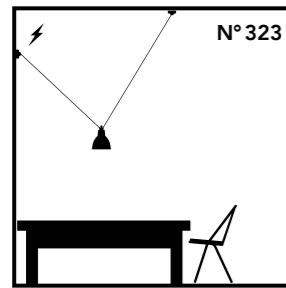
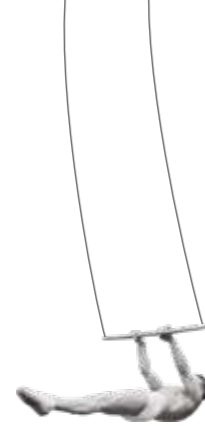

fig. A

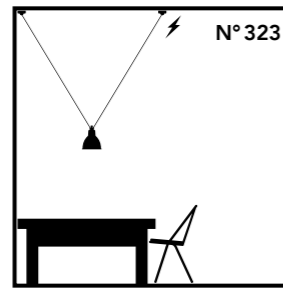

fig. B

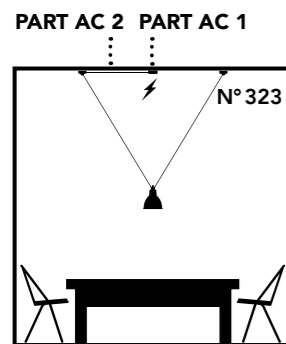

fig. C

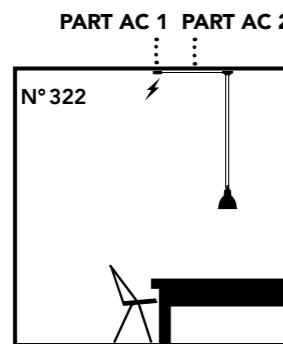

fig. D

⚡ : Point électrique | Electric point

Si votre alimentation électrique n'est pas située à l'endroit précis où vous souhaitez l'éclairage, les Acrobates de GRAS vous permettent de résoudre votre problématique. (Sans accessoire: fig. A et B, ou avec accessoire fig. C, D, E, F, G, H, I, J).

**English** • If there is no electrical connection at the exact point you want to install your lamp, Les Acrobates de GRAS are the answer to your problem. (Either without use of an accessory - figures A and B - or with an accessory - figures C, D, E, F, G, H, I, J).

**Deutsch** • Wenn Ihre Steckdose ungünstig platziert ist, sind les Acrobates de GRAS die Lösung (ohne Accessoire Fig. A + B, oder mit Accessoire Fig. C, D, E, F, G, H, I, J).

**Italiano** • Se la vostra fonte d'alimentazione non é situata nel luogo preciso in cui volete illuminare, les Acrobates de GRAS permettono di risolvere questo problema. (Senza accessori: fig. A e B o con accessori fig. C, D, E, F, G, H, I, J).

**Español** • Si la alimentacion eléctrica no se encuentra en el lugar indicado, donde usted desea la luz, los Acrobates de GRAS le permitiran resolver está problematica. (Sin accesorios figura A y B o con accesorios figura C, D, E, F, G, H, I, J).

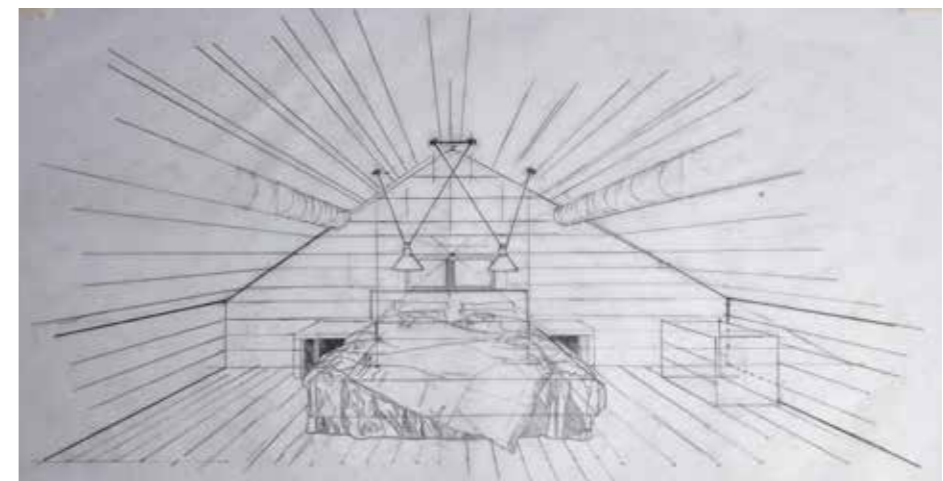
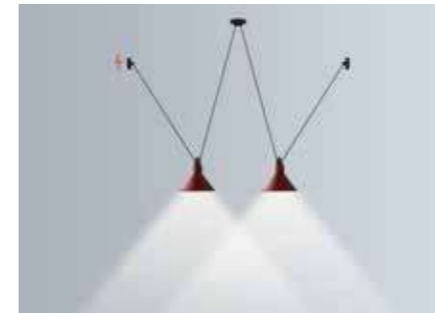

2 x N° 323 + PART AC2

# COMPOSER COMPOUND

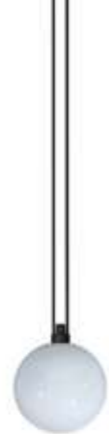

À partir d'une seule source d'électricité, et en utilisant le ou les accessoires AC1 - AC2 - AC3, il est possible d'effectuer une multitude de compositions, aussi bien en ligne que sur 2 axes.

**English** • From a single electrical point, using either or both of the AC1 - AC2 - AC3 accessories it is possible to create a multitude of different compositions, whether linear or outwards from a central point.

**Deutsch** • Es steht nur eine Steckdose zur Verfügung. Dann ermöglichen die Teile AC1 - AC2 - AC3 eine Vielzahl von Kompositionen (bis zu 2 achsig).

**Italiano** • A partire da una sola fonte di elettricità, usando il/gli accessori AC1 - AC2 - AC3, è possibile creare diverse composizioni sullo stesso asse o su 2 assi.

**Español** • A partir de una sola fuente de electricidad, y en la utilización de el o los accesorios AC1 - AC2 - AC3, será posible de efectuar una cantidad de composiciones, también sobre una línea o sobre los 2 axesos.

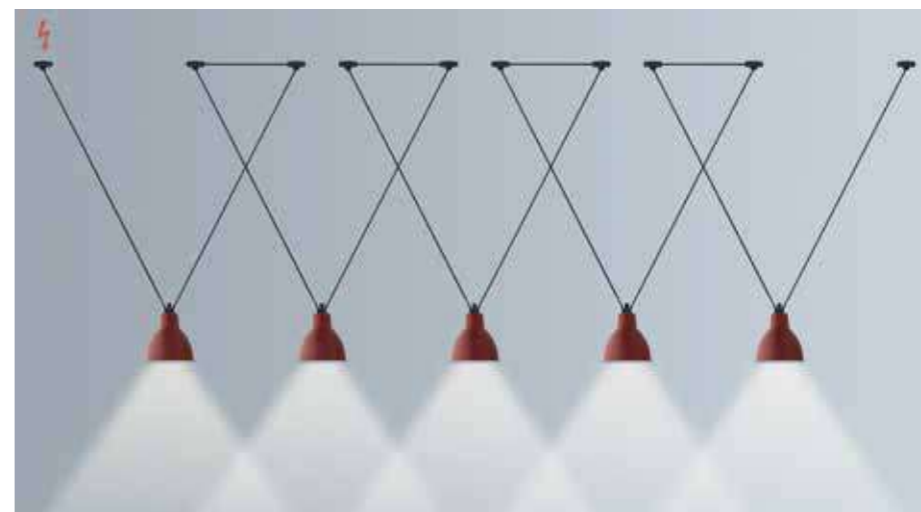
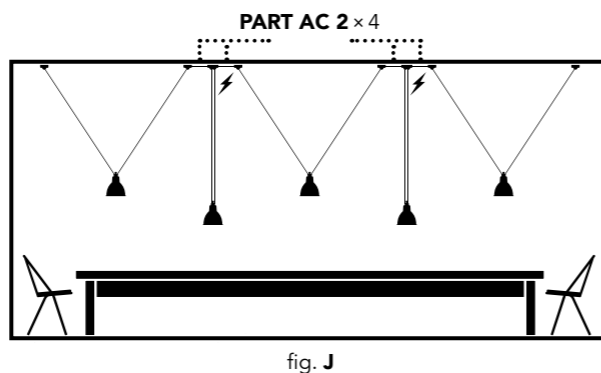
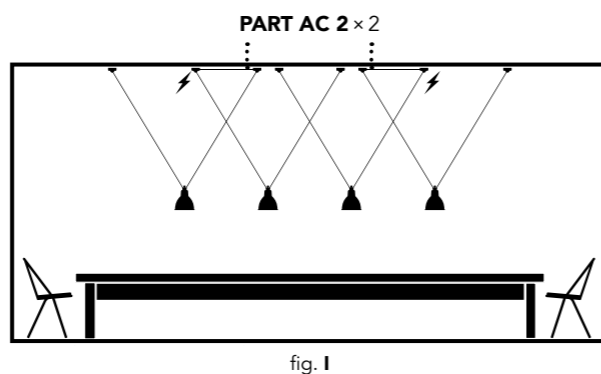
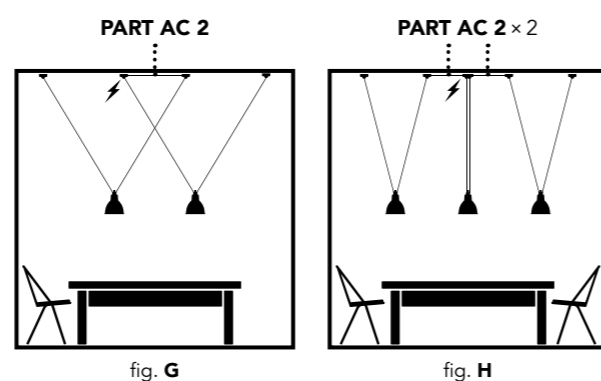
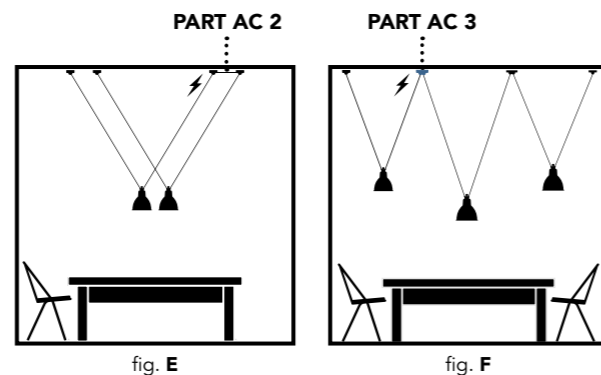





Left page  
N° 322 GLASS  
BALL Ø250

Right page  
N° 322 L YELLOW  
CONIC





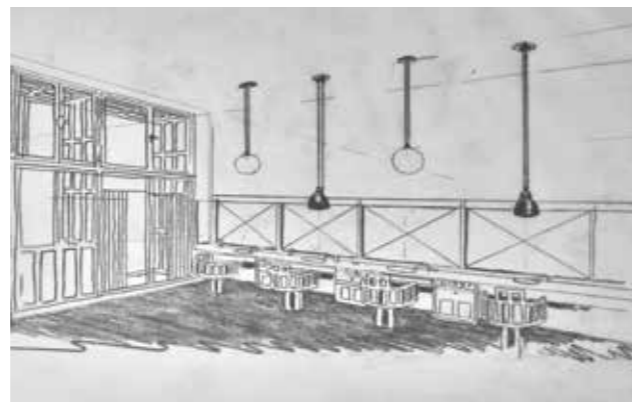
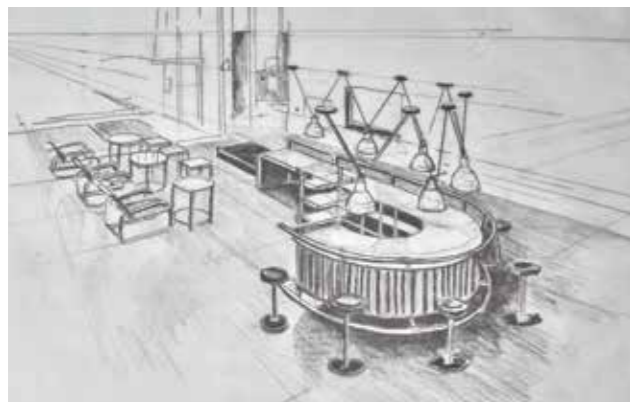
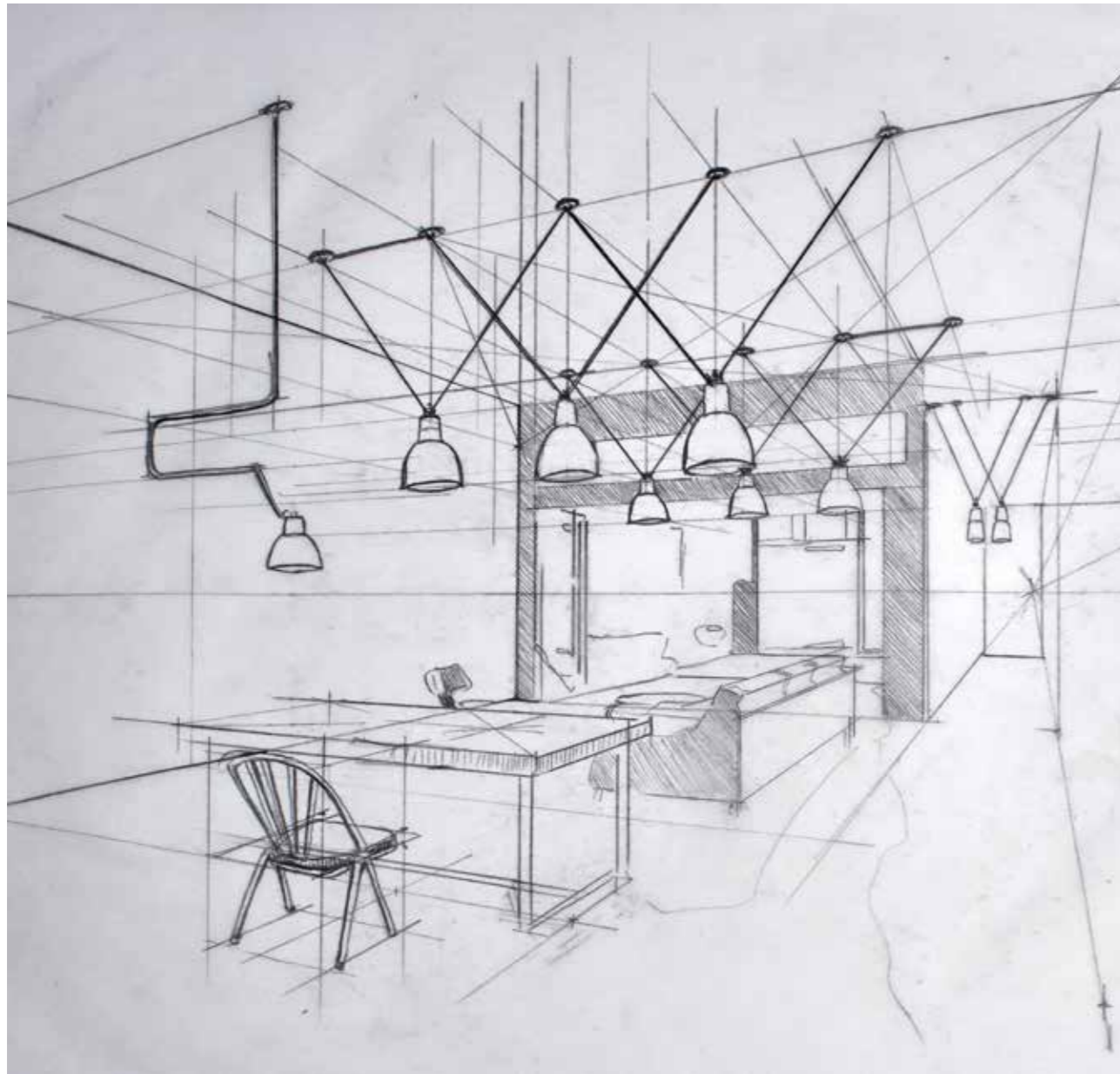

N° 323 L BLACK CONIC





Left page  
N° 322 + N° 323 L  
BLACK CONIC

Right page  
N° 323 L BLACK  
COPPER ROUND





N° 325 L BLACK ROUND

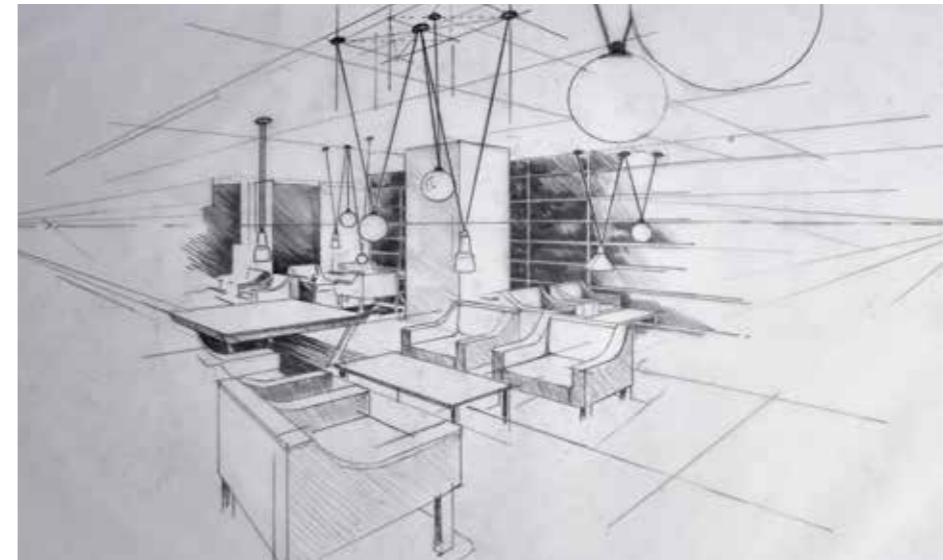

N° 325





Left page : 2 x N° 323 XL RED CONIC  
Right page : N° 323 + N° 324 L BLACK & BRASS ROUND + PART AC 3



N° 326 L BLACK ROUND



N°327 L BLACK ROUND + GLASS BALL Ø 250



N° 326 GLASS BALL Ø 175



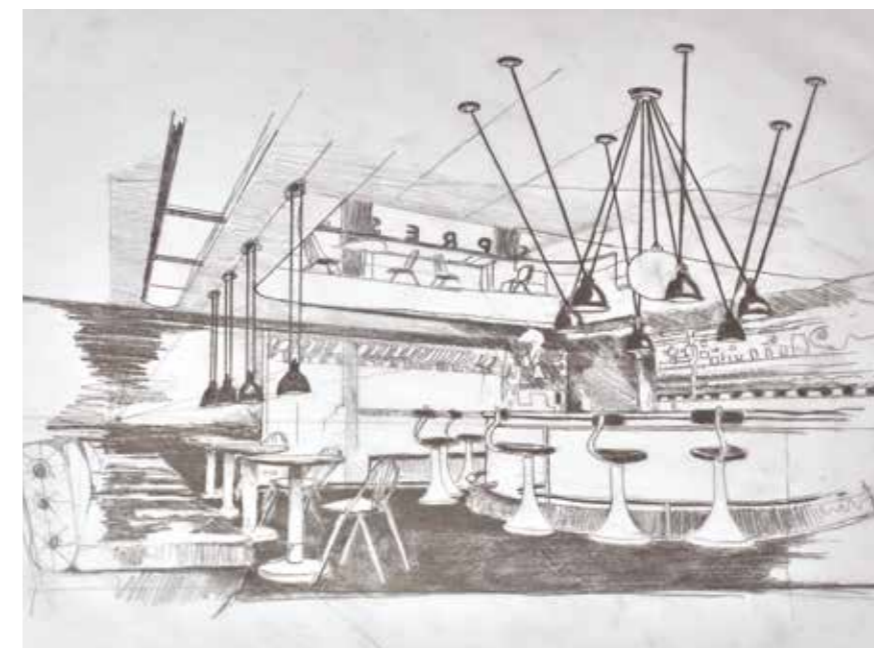

Left page  
N° 323 XL BLACK  
ROUND

Right page  
N° 327 L BLACK  
ROUND + GLASS  
BALL Ø 250



Left page  
N° 323 BLACK  
ROUND

Right page  
N° 323 BL  
GLASS BALL  
Ø 175





› TABLE, FLOOR,  
CEILING & WALL  
LAMPS

TABLE LAMPS

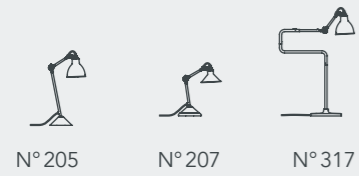

ARCHITECT AND BOOKSHELF LAMPS

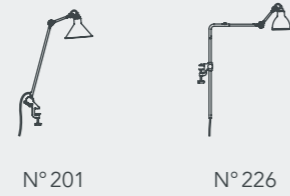

FLOOR LAMPS



WALL LAMPS

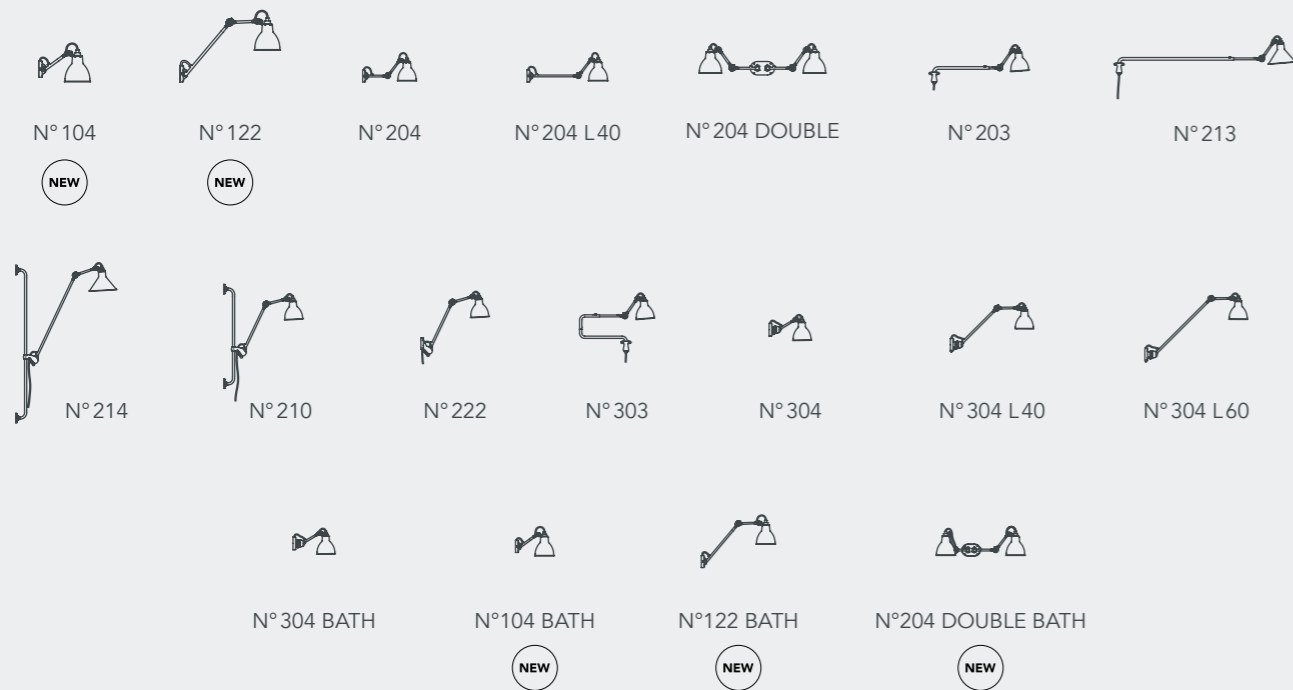

# LA LAMPE GRAS™

de Bernard-Albin Gras

CEILING LAMPS



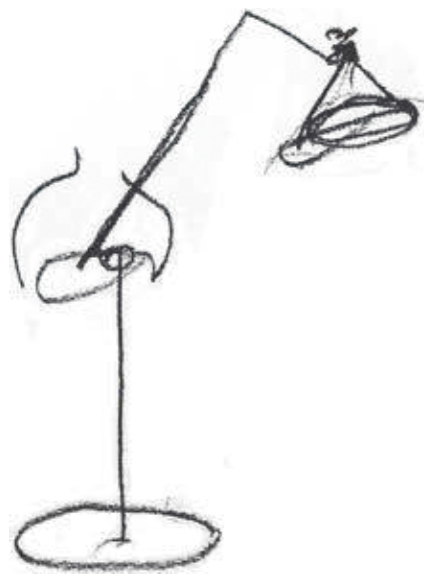

# LA LAMPE GRAS™

de  
Bernard-  
Albin Gras

## UNE ICÔNE DU XX<sup>e</sup> SIÈCLE

En 1921, **Bernard-Albin Gras** crée une gamme de lampes pour l'industrie et les bureaux d'études.

**La Lampe GRAS** est étonnante par son ergonomie et la simplicité de sa mécanique – ni vis, ni soudure – qui lui confère une robustesse à toute épreuve. Mais Bernard-Albin Gras est aussi un des premiers designers du xx<sup>e</sup> siècle: non content d'innover, il ajoute à ses créations une esthétique fonctionnelle originale notamment dans le dessin des bases et des bielles.

Très rapidement, Le Corbusier, séduit par la modernité de son dessin et sa qualité d'utilisation, adopte la gamme des lampes GRAS et l'intègre dans son agence ainsi que dans ses nombreuses réalisations à travers le monde. La Lampe GRAS entre alors dans la légende. Suivront Robert Mallet-Stevens, Jacques-Emile Ruhlmann, Eileen Gray, mais également Sonia Delaunay, Georges Braque...

C'est la première fois dans l'histoire de l'éclairage qu'une lampe est utilisée dans les ateliers, les maisons et les appartements. Aujourd'hui cette lampe est collectionnée par les amateurs à travers le monde notamment en France, aux États-Unis et au Japon. Le sens inné de l'esthétique de Bernard-Albin Gras a traversé le temps.

DCW éditions a acquis l'exclusivité des droits de la gamme des lampes GRAS.

## English • AN ICON OF 20<sup>TH</sup> CENTURY

In 1921 **Bernard-Albin Gras** designed a series of lamps for use in offices and in industrial environments. The **Lampe GRAS**, as it was subsequently called, was astounding in its simple, robust and yet very ergonomic design. There are neither screws nor welded joints in the basic form.

In 1927 the Ravel company purchased the patent and started production of the Lampe GRAS. Bernard-Albin Gras was one of the most innovative designer of the 20<sup>th</sup> century. The functional esthetic of his lamps and especially the design of details such as those of the articulated brackets, supports and bases were truly original and far ahead of his time.

Early on Le Corbusier was seduced by the modern design and userfriendliness of the lamps and became one of Bernard-Albin Gras most enthusiastic supporters using the lamps in his own offices as well as employing them in numerous architectural projects all over the world. Others such as Robert Mallet-Stevens, Jacques Emile Ruhlmann and Eileen Gray followed this trend as well. Furthermore, such well-known artists as Sonia Delaunay and Georges Braque also used these lamps in their studios.

For the first time in history, a lamp was equally popular in professional as well as in residential

applications. Today, the Lampe GRAS has become sought after a collector's item all over the world, most notably in France, in the United States and in Japan. Bernard-Albin Gras talented and visionary design has proven to be timeless.

DCW éditions has acquired exclusive rights for the range of Lampes GRAS.

## Deutsch • EIN IKONE DES 20. JAHRHUNDERTS

1921 entwickelte **Bernard-Albin Gras** eine Serie von Leuchten für Industrie und Konstruktionsbüros. Die **Lampe GRAS** – wie sie künftig benannt wird, verblüfft durch ihre Ergonomie und einfache Mechanik: keine Schraube, keine Schweißnaht und sie überzeugt durch ihre Robustheit und Langlebigkeit.

1927 erwirbt die Firma Ravel das Patent und startet mit der Produktion der Lampe GRAS. Bernard-Albin Gras war einer ersten Designer des 20. Jahrhunderts. Er fügte der Funktion ein sensibles Design und eine auch heute akzeptierte Formensprache

hinzu. Die Details der Beweglichkeit und die spezielle Formgebung des Sockels überzeugen immer wieder. Technische Feinessen wie die einzigartige Arretierung der Glieder und der Neigung zaubern ein Lächeln hervor. Bald überzeugt die Lampe GRAS Le Corbusier durch Ihre Funktionalität und Ihrem einzigartigen Design. Als ein begeisterter Nutzer setzt er die Leuchte in seinen eigenen Büros ebenso ein wie in zahlreichen Projekten weltweit. Andere wie Robert Mallet-Stevens, Jacques Emile Ruhlmann, Eileen Gray sind ebenso begeistert wie auch Sonia Delaunay, Georges Braque u.v.a.. Das erste Mal in der Geschichte wird eine Leuchte im professionellen Bereich wie der Büros oder der Industrie ebenso eingesetzt wie im privaten Umfeld, und damit wird die Lampe GRAS zur Legende.

Heute ist die Lampe GRAS ein gefragtes Sammlerstück insbesondere in Frankreich, den Vereinigten Staaten, in Japan und der Schweiz. Bernard-Albin Gras' visionäres Design überdauert die Zeiten!

DCW éditions hat die exklusiven Markenrechte erworben der Lampe GRAS.

## Italiano • UN' ICONA DEL XX SECOLO

Nel 1921 **Bernard-Albin Gras** ha disegnato una serie di lampade per uso in uffici ed in ambienti industriali. **La Lampe GRAS**, come fu successivamente denominata, era eccezionale per il suo design semplice, robusto anche se eccessivamente ergonomica. Non vi sono né viti né giunti saldati nella forma di base.

Nel 1927 la società Ravel ne ha acquistato il brevetto ed ha dato avvio alla produzione delle lampade GRAS. Bernard-Albin Gras è stato uno dei più innovativi designer del 20mo secolo. L'estetica funzionale delle sue lampade ed in particolare il design dei dettagli come quelli dei bracci, steli, staffe e basi erano effettivamente originali e molto avanti rispetto i tempi.

In precedenza Le Corbusier è stato sedotto dal moderno design e dalla facilità d'uso delle lampade e divenne uno dei più entusiasti sostenitori di Bernard-Albin Gras facendo





uso delle lampade nei suoi uffici e facendone uso in numerosi progetti architettonici in tutto il mondo. Altri come Robert Mallet-Stevens, Jacques Emile Ruhlmann ed Eileen Gray hanno seguito questo trend. Inoltre, famosi artisti come Sonia Delaunay e Georges Braque hanno anche utilizzato queste lampade nei loro studi.

Per la prima volta nella storia, una lampada era parimenti popolare in applicazioni professionali e residenziali. Al giorno d'oggi, la Lampe GRAS è richiesta in tutto il mondo come un oggetto da collezione, principalmente in Francia, negli Stati Uniti ed in Giappone. Il design visionario e di talento di Bernard-Albin Gras ha dimostrato di essere atemporale.

DCW éditions ha ottenuto i diritti esclusivi per la gamma delle Lampes GRAS.

#### Español • UN ICONO DEL SIGLO XX

En 1921, **Bernard-Albin Gras** creó una gama de lámparas para la industria y las oficinas. La **Lampe GRAS** sorprende por su ergonomía y por la sencillez de su mecánica – ni tornillos, ni soldaduras – que le ofrecen una robustez a toda prueba. Pero Bernard-Albin Gras también es uno de los primeros diseñadores del siglo XX: además de innovar, añade a sus creaciones una estética funcional original, en particular en el diseño del hierro fundido y de las bielas.

Muy rápidamente, Le Corbusier, seducido por la modernidad de su diseño y por su funcionalidad, adopta la gama de las lámparas GRAS y las integra en su agencia así como en sus numerosos proyectos a través del mundo. La Lampe GRAS entró en la leyenda. Seguido por Robert Mallet-Stevens, Jacques-Emile Ruhlmann, Eileen Gray, así como Sonia Delaunay, Georges Braque.

Por primera vez en la historia de la iluminación, una lámpara se utiliza en las fábricas y en las casas. Hoy, esta lámpara se colecciona en todo el mundo, en particular en Francia, Estados Unidos y Japón. El sentido innato de la estética de Bernard-Albin Gras perdura en el tiempo.

DCW éditions ha adquirido la exclusiva de los derechos de la gama de las lámparas GRAS.



Le Corbusier dans son atelier



# LES COULEURS DE GRAS

par Pierre Bonnefille

Nous avons demandé à Pierre Bonnefille, coloriste talentueux, Maître d'Art, d'habiller de couleurs les réflecteurs de la lampe GRAS. Le ROUGE BOLUS, ce rouge mystérieux qui donne aux feuilles d'or ses reflets. Le JAUNE CALME et silencieux, couleur de l'huile des machines. Le BLEU CARBONE en souvenir du papier carbone. Le BLANC NEIGE, avec intérieur blanc ou cuivre. Le NOIR des nuits profondes, avec intérieur blanc ou cuivre. Le CUIVRE CHAUD pour les nuits douces.

**English** • We invited Pierre Bonnefille, a talented colourist and a "Maître d'Art" to colour the Lampe GRAS. Lampshades RED BOLUS the mysterious red that gives gold leaf its shimmering qualities. "RESTFUL" YELLOW, colour of machine oil, DEEP BLUE, reminiscent of that used in carbon paper, WHITE of the snow, with white inside or copper inside, DARK BLACK of the night, with white inside or copper inside. HOT COPPER for sweet night.

**Deutsch** • Pierre Bonnefille, ein talentierter Farbkünstler und "Maître d'Art", setzt charakteristische Akzente der Lampenschirme der Lampe GRAS. Das ROUGE BOLUS, ein Rot, das dem Blattgold seinen leuchtenden Charakter gibt. RUHIGES GELB, die Farbe des Maschinenöls. TIEFES BLAU erinnert an das Kohlepapier. Schneewittchen, innen weiss oder kupferfarbig. DAS SCHWARZ der dunklen Nächte, innen weiss oder kupferfarbig. WARMES KUPFER für besinnliche und müssige Nächte.

**Italiano** • Abbiamo invitato Pierre Bonnefille, un colorista di talento, "Maître d'Art", di rivestire di colore i riflettori della Lampe GRAS. "ROSSO BOLUS", misterioso "rosso bolus", quel rosso che dà i suoi riflessi alle foglie d'oro GIALLO "RIPOSANTE", il colore dell'olio per macchine BLU PROFONDO, che ricorda la carta carbone BIANCO DELLA NEVE, con interno bianco o rame NERO SCURO, con interno bianco o rame RAME CALDO per una dolce notte.



Pierre Bonnefille

**Español** • Hemos pedido al "Maestro" Pierre Bonnefille, colorista de gran talento, que vista con colores los reflectores de la lámpara GRAS. El ROJO BOLUS, un rojo enigmático, misterioso que proporciona un reflejo dorado a las hojas. Un AMARILLO TENUE, del color del aceite industrial. El AZUL CARBONE, que nos recuerda el azul del papel carbón. El BLANCO APAGADO, con el interior blanco o color cobre. El NEGRO de las noches profundas, con el interior blanco o cobrizo. El COLOR COBRE, cálido para las noches apacibles.

Pierre Bonnefille is the creator of the ARGILE range of paints.

[www.pierrebonnefille.com](http://www.pierrebonnefille.com)

# LES RÉFLÉCTEURS DE GRAS

Chaque Lampe GRAS (excepté la N° 207) peut recevoir 2 formes de réflecteurs, en 13 finitions dont 6 en cuivre et 1 en verre sablé. Facile à changer: 20 secondes!

**English** • All Lampe GRAS (except for N° 207) can take 2 kinds of shades, in 13 different finishes of which 6 of copper and 1 frosted glass. Easily changed: 20 seconds!

**Deutsch** • Alle Lampe GRAS – Leuchten sind in zwei Lampenschirm-Formen erhältlich (mit Ausnahme der N° 207), in 13 Ausführungen, davon 6 mit Kupfer und 1 Satiniertes Glas. Einfach auszutauschen: in 20 Sekunden!

**Italiano** • Tutte le Lampe GRAS (ad eccezione della N° 207) può prendere 2 tipi di riflettori, in 13 finiture di cui 6 in rame e 1 vetro smerigliato. E' facile da cambiare: 20 secondi!

**Español** • Todas las lámparas GRAS (excepto el mod. N° 207), admiten dos tipos de reflectores, con 13 acabados, 6 de ellos en cobre y 1 vidrio mate. ¡Fáciles de cambiar, sólo se necesitan 20 segundos!



## CONIC



**\*WARNING**  
Le RAW COPPER est livré brut et poli, d'aspect neuf. La patine évolue avec le temps.  
The RAW COPPER is delivered as called RAW. The patina will evolve time after time.

## ROUND



## GLASS BALL





LAMPE  
DE TABLE  
TABLE LAMP

# N° 205



N° 205 BL-BL

FINISHES



BLACK



N° 205 BL-BRASS



Left page: N° 205 BL\_BLACK  
Right page: N° 205 BL\_YELLOW





LAMPE  
DE TABLE  
TABLE LAMP

N° 207



N° 207 BL-BL



LAMPE  
DE TABLE  
TABLE LAMP

N° 317



N° 317 BL-BL





# LAMPE D'ARCHITECTE ARCHITECT LAMP

# N° 201



N° 201 BL-BL



# LAMPE D'ÉTAGÈRE BOOKSHELF LAMP

# N° 226



N° 226 BL-BL | N° 226 BL-YELLOW





# LAMPADAIRES FLOOR LAMPS

# N° 215 N° 411



N° 215  
(E 14)



N° 411  
(E 27)



N° 215 BL-BL



Left page: N° 215 BL-RED  
Right page: N° 215 BL-BLUE







N° 411 BL-BRASS | N° 411 BL-BLUE





# APPLIQUES WALL LAMPS

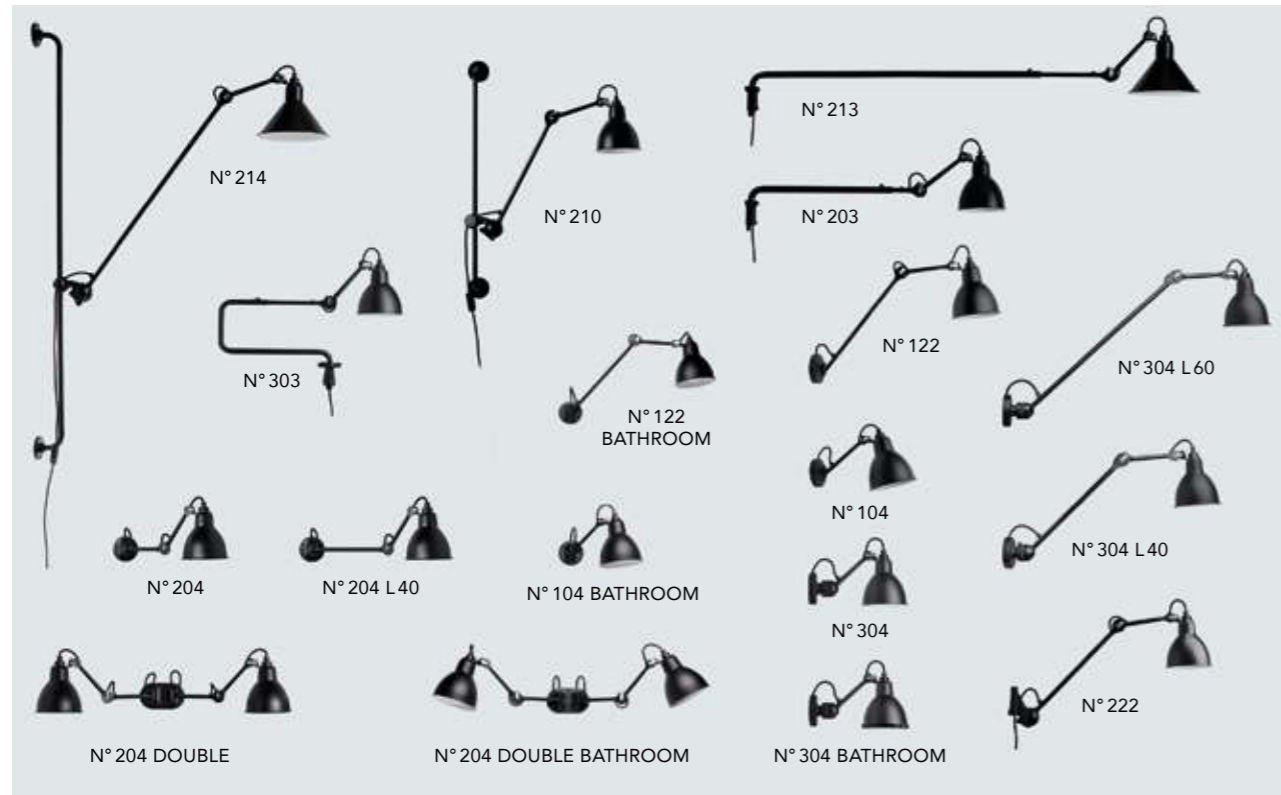

La collection d'appliques Lampe Gras couvre un nombre important d'usages.

L'utilisation d'appliques permet de créer une atmosphère particulière... L'accroche visuel de l'objet et la lumière dégagée personnifient l'espace.

Chaque référence est à l'aise dans de nombreuses situations. Mais il y a toujours un modèle qui est plus performant qu'un autre, dans une utilisation bien précise.

Par exemple, en tête de lit nous recommandons les appliques N° 203, N° 204, N° 204 L40, N° 210, N° 303 et l'applique N° 204 Double.

En tête de lit, le luminaire doit être agile, c'est la raison pour laquelle les nouveautés : N° 104 et N° 122 utilisent le pivot comme N° 204, N° 204

Double, N° 204 L40. Dans les couloirs, entrées, en mural sur un plan de travail... les appliques N° 222, N° 304, N° 304 L40 ou L60. Mais ces modèles peuvent aussi être utilisés en plafonnier si la hauteur de plafond est peu élevée.

Pour la salle de bain, dans la collection Lampe Gras, seules les N° 304 Bathroom et N° 304 XL OUTDOOR SEA sont IP 64.

Trois nouveaux modèles complètent l'équipe. Courtes, obliques ou doubles, les LAMPE GRAS N° 104 Bathroom, N° 122 Bathroom et N° 204 Double Bathroom s'intègrent à toutes les morphologies de salle de bain.

IP44: l'étui de verre sablé se visse dans l'abat-jour pour encapsuler l'ampoule E27.

**Deutsch** • Die Wandleuchtenkollektion von Lampe Gras ist vielseitig einsetzbar.

Die Wandleuchten ermöglichen es, eine besondere Atmosphäre zu schaffen... Die visuelle Blickfang des Objekts und das tageslichtähnliche Licht vermitteln ein Raumgefühl.

Jedes Produkt verleiht in vielen Situationen ein Gefühl der Entspannung.

Aber es gibt immer ein Modell, das sich in einer bestimmten Anwendung besser eignet als ein anderes. So empfehlen wir für das Kopfende des Bettes die Wandleuchten N° 203, N° 204, N° 204 L40, N° 210, N° 303, N° 204 Double.

Nachttischleuchten müssen flexibel sein. Deshalb verwenden die neuen Modelle N° 104, N° 122 den gleichen Drehmechanismus wie die Modelle N° 204, N° 204 L40 und N° 204 double.

In Fluren, Foyers, an der Wand über einer Arbeitsfläche... die Wandleuchten N° 222, N° 304, N° 304 L40 oder L60. Aber diese Modelle können auch an niedrigen Decken verwendet werden.

Für Badezimmer sind in der Kollektion von Lampe Gras nur N° 304 Bathroom und N° 304 XL OUTDOOR SEA IP 64.

Drei neue Modelle vervollständigen das Team.

Ob kurz, schräg oder doppelt, die LAMPE GRAS N° 104 Bathroom, N° 122 Bathroom und N° 204 Double Bathroom passen in alle Badezimmer-Morphologien.

IP44: Das sandgestrahlte Glasgehäuse wird in den Schirm geschraubt, um die E27-Glühbirne zu umschließen.

**English** • The Lampe Gras collection covers a wide variety of uses.

Wall-mounted, they contribute to creating a room's atmosphere. The object's appearance and the light it diffuses help to give character to a space.

Each reference can be used in a multitude of settings. But for a given situation, there is always one particular model which corresponds better than all the others for the specific conditions in which it will be used.

For example, for bedheads, we recommend shades N° 203, N° 204, N° 204 L40, N° 210, N° 303 and N° 204 Double.

Bedside lights need to be flexible. That's why new models N° 104 and N° 122 use the same pivot mechanism as N° 204, N° 204 L40, N° 204 Double.

In corridors, entrances or wall-mounted over a worktop, shades N° 222, N° 304, N° 304 L40 or L60 are ideal. But the same models can also be used as ceiling lamps, provided the ceiling height is not too high.

For the bathroom, in the Lampe Gras collection only models N° 304 Bathroom and N° 304 XL OUTDOOR SEA are IP 64.

Three new models complete the team.

Short, slanted or double, the LAMPE GRAS N° 104 Bathroom, N° 122 Bathroom and N° 204 Double Bathroom fit all bathroom morphologies.

IP44: the sandblasted glass case is screwed into the shade to encapsulate the E27 bulb.



**Italiano** • La collezione di applique Lampe Gras copre un gran numero di utilizzi.

L'utilizzo di applique consente di creare un'atmosfera speciale... L'approccio visivo dell'oggetto e la luce definita personalizzano lo spazio.

Ogni articolo è a proprio agio nelle varie situazioni. Ma c'è sempre un modello che è più performante di un altro in una condizione di utilizzo ben precisa. Ad esempio, sulla testiera del letto noi raccomandiamo le applique N° 203, N° 204, N° 204 L40, N° 210, N° 303 e la applique N° 204 Double.

Le lampade da lettura a parete per il letto devono essere flessibili. Ecco perché le nuove N° 104, N° 122 utilizzano lo stesso meccanismo di rotazione delle N° 204, N° 204 Doppia, N° 204 L40.

Nei corridoi, negli atri, alla parete sopra un piano di lavoro... le applique N° 222, N° 304, N° 304 L40 o L60. Tuttavia, questi modelli possono essere utilizzati anche sul soffitto, se l'altezza del soffitto è poco elevata. Per il bagno, nella collezione Lampe Gras, solo N° 304 e N° 304 Bathroom e N° 304 XL OUTDOOR SEA sono IP64.

Tre nuovi modelli completano la squadra. Corto, obliquo o doppio, la LAMPE GRAS N° 104 Bathroom, N° 122 Bathroom e N° 204 Double Bathroom, si adattano a qualsiasi morfologia di bagno. IP44: l'involucro di vetro sabbiato è avvitato al paralume per incapsulare la lampadina E27.

**Español** • La colección de apliques de pared Lampe Gras abarca una amplia gama de usos.

El uso de apliques permite crear una atmósfera particular... El atractivo visual del objeto y la iluminación producida personifican el espacio.

Cada modelo resulta cómodo en múltiples situaciones. Pero siempre hay un modelo más eficiente que otro en un uso específico.

Por ejemplo, para la cabecera de la cama, recomendamos los apliques N° 203, N° 204, N° 204 L40, N° 210, N° 303 y la doble N° 204 Double.

En la cabecera de la cama, la luminaria debe ser ágil, por eso los nuevos modelos: N° 104, N° 122 utilizan el pivote como la lámpara N° 204, N° 204 Doble, N° 204 L40.

En pasillos, recibidores, en pared sobre una superficie de trabajo... los apliques N° 222, N° 304, N° 304 L 40 o L60. Aunque estos modelos también se pueden utilizar como plafón si la altura del techo es baja.

Para el cuarto de baño y dentro de la colección Lampe Gras, únicamente el N° 304 Bathroom y el N° 304 XL OUTDOOR SEA son IP64.

Tres nuevos modelos completan el equipo. Corto, oblicuo o doble, las lámparas GRAS N° 104 Bathroom, N° 122 Bathroom y N° 204 Doble Bathroom se adaptan a todas las formas de baño. IP44: la protección de vidrio mate se atornilla a la pantalla para encapsular la bombilla E27.



# APPLIQUES & TÊTES DE LIT

## WALL & BEDSIDE LAMPS

NEW

# N° 104



En tête de lit,  
système de pivot  
pour plus de  
fluidité.

For bedside lamps,  
pivot system gives  
more fluidity.

NEW

# N° 122



En tête de lit,  
système de pivot  
pour plus de  
fluidité.

For bedside lamps,  
pivot system gives  
more fluidity.





N° 104 BL-RED



N° 122 BL-BL

# APPLIQUES & TÊTES DE LIT

## WALL & BEDSIDE LAMPS

# N° 204



**N° 204 DOUBLE**  
(E 27)



**N° 204 L 40**  
(E 27)



**N° 204**  
(E 27)



N° 204 BL-BL





N° 204 L40 BL-BL



N° 204 DOUBLE BL-BL

# APPLIQUES WALL LAMPS

## N° 304



**N° 304**  
Without switch



**N° 304 SW**  
With switch on the base



**N° 304 CA**  
With switch on the cable



**N° 304 XL OUTDOOR SEA**  
IP 64 - Dust and wet resistant  
**INOX 316**

### FINISHES

**N° 304 &  
N° 304 BATHROOM**



BLACK

**N° 304 OUTDOOR**



BLACK



N° 304 BL-RED



# APPLIQUES WALL LAMPS

## N° 304 L 60

## N° 304 L 40

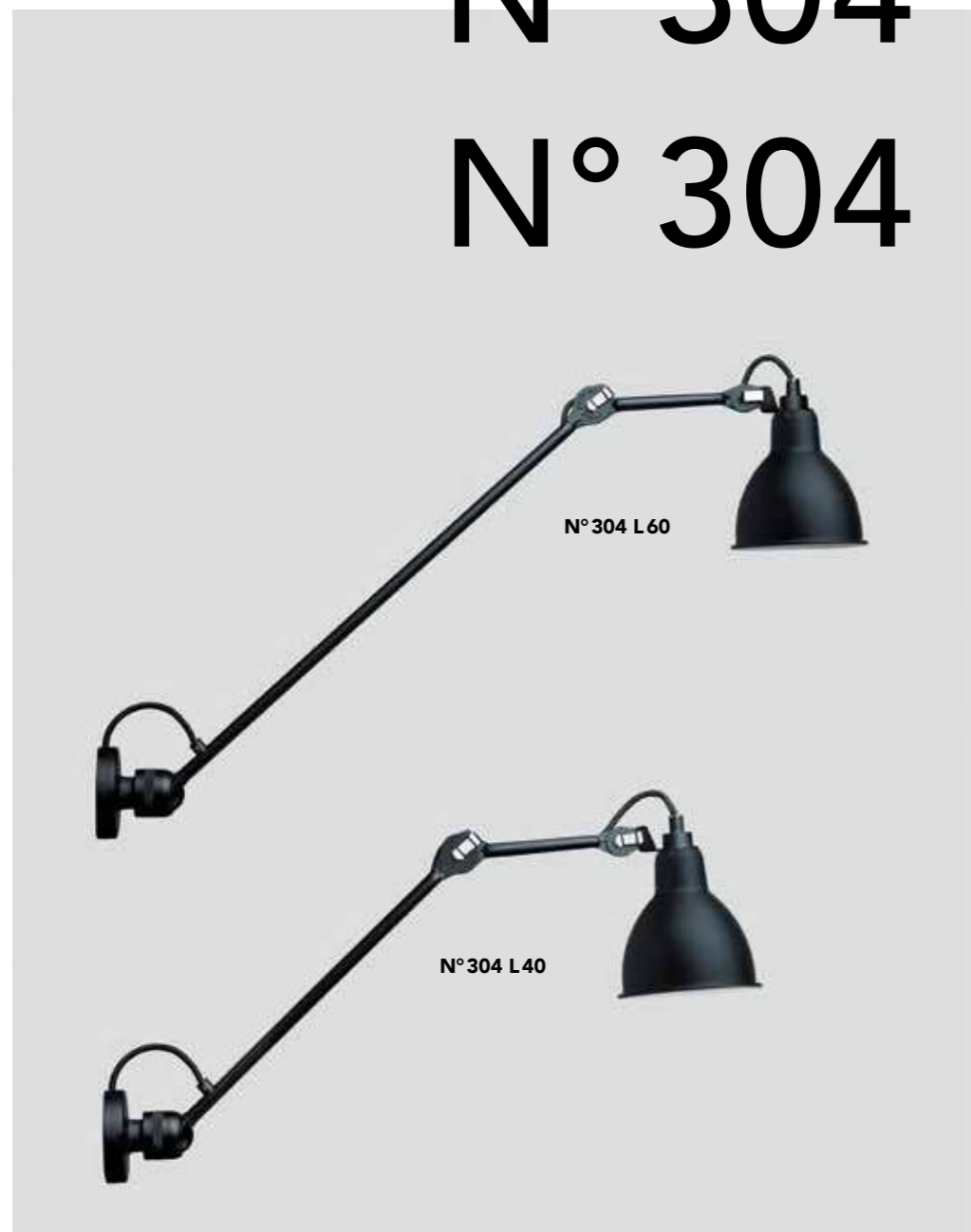

3 x N° 304 L 40 BL-RED

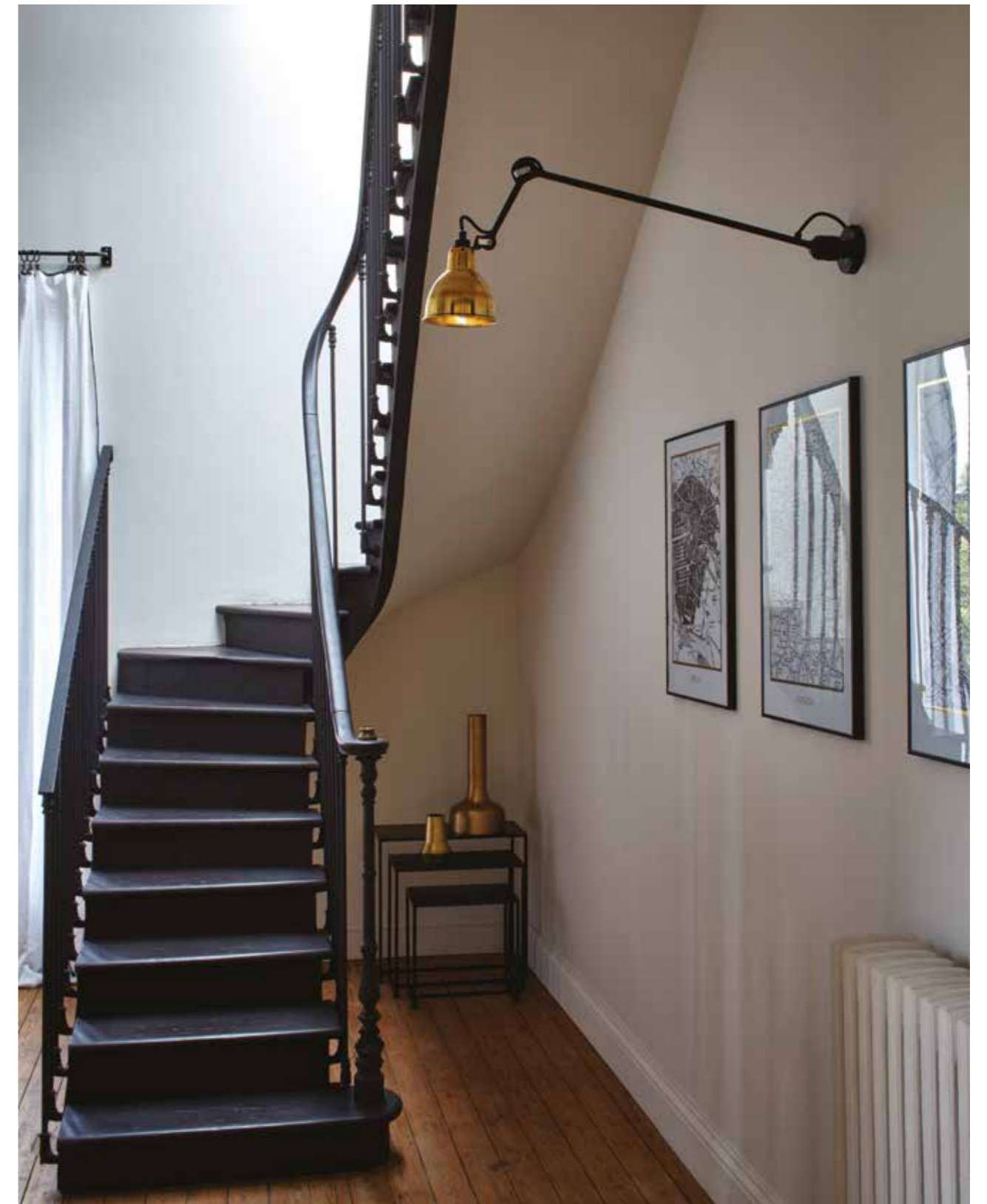

2 x N° 304 L60 BL-BL | N° 304 L60 BL-BRASS



# APPLIQUE WALL LAMP

## N° 203

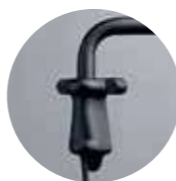

Une plaque  
d'ornement acier  
est fournie avec la  
lampe N° 203

An ornamental  
steel plate is  
included with the  
lamp N° 203



2 x N° 203 BL-BL

# APPLIQUES & TÊTES DE LIT

## WALL & BEDSIDE LAMPS

# N° 303

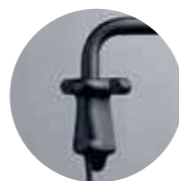

Une plaque  
d'ornement acier  
est fournie avec la  
lampe N° 303

An ornamental  
steel plate is  
included with the  
lamp N° 303



2 x N° 303 BL-BL



# APPLIQUE WALL LAMP

# N° 213

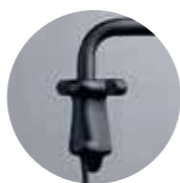

Une plaque  
d'ornement acier  
est fournie avec la  
lampe N° 213

An ornamental  
steel plate is  
included with the  
lamp N° 213

## FINISHES



BLACK

N° 213 BL-BL | N° 213 BL-RED





# APPLIQUE WALL LAMP

# N° 222



Une plaque  
d'ornement acier  
est fournie avec la  
lampe N° 222

An ornamental  
steel plate is  
included with the  
lamp N° 222

## FINISHES



BLACK





# APPLIQUES & TÊTES DE LIT

WALL & BEDSIDE LAMPS

## N° 210



N° 210 BL-BL

# APPLIQUE

WALL LAMP

## N° 214



N° 214 BL-BL







N° 214 BL-BL

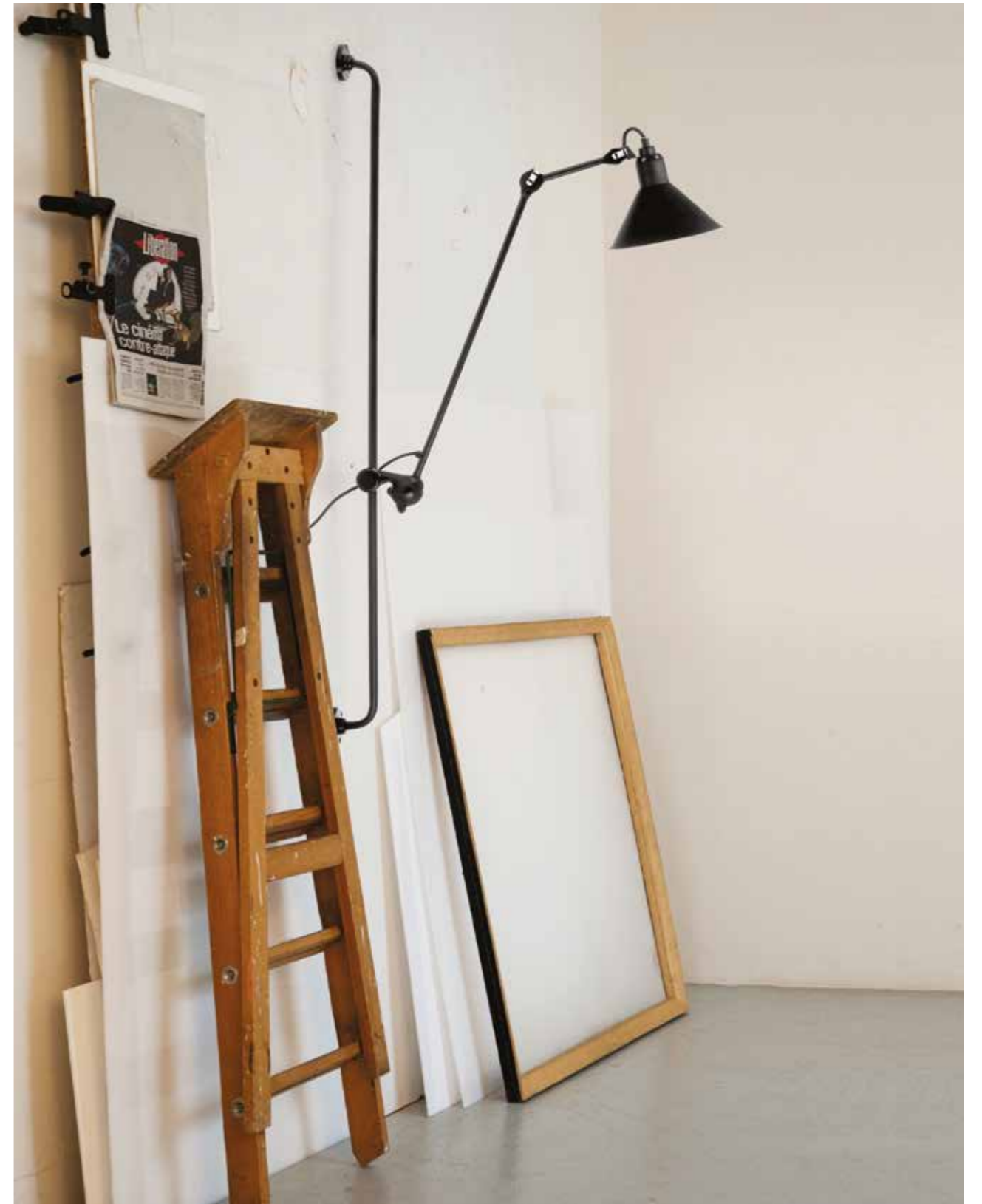

N° 214 BL-BL

# PLAFONNIERS CEILING LAMPS

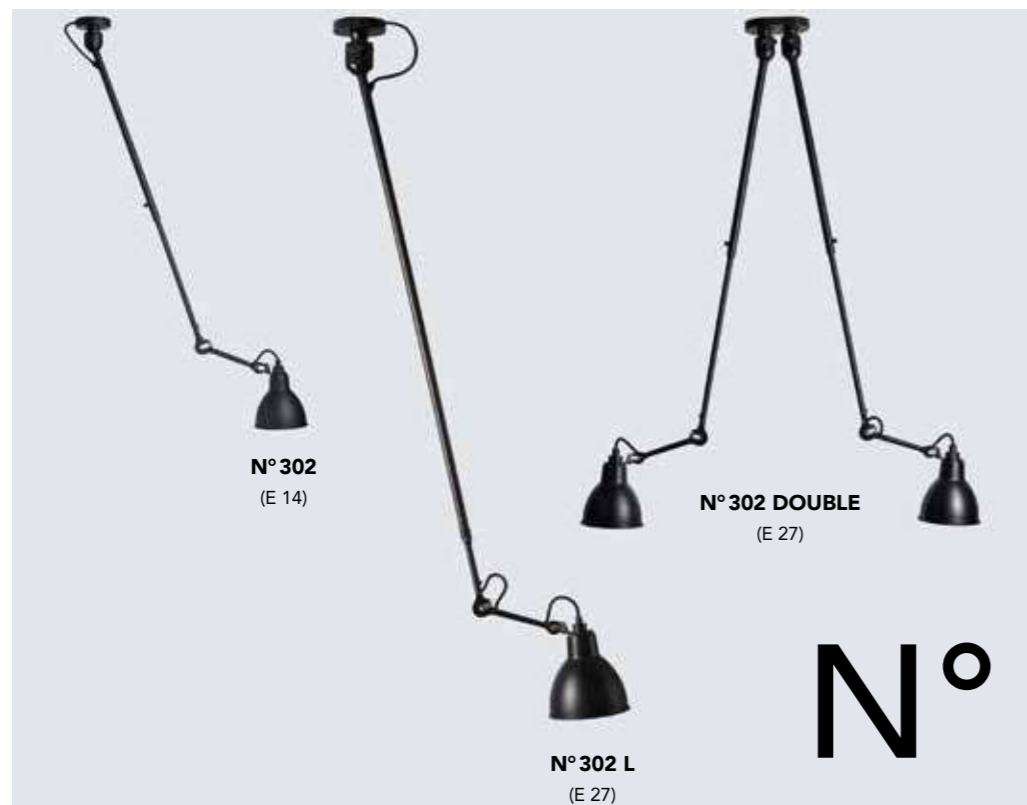

N° 302  
N° 302 L  
N° 302  
DOUBLE

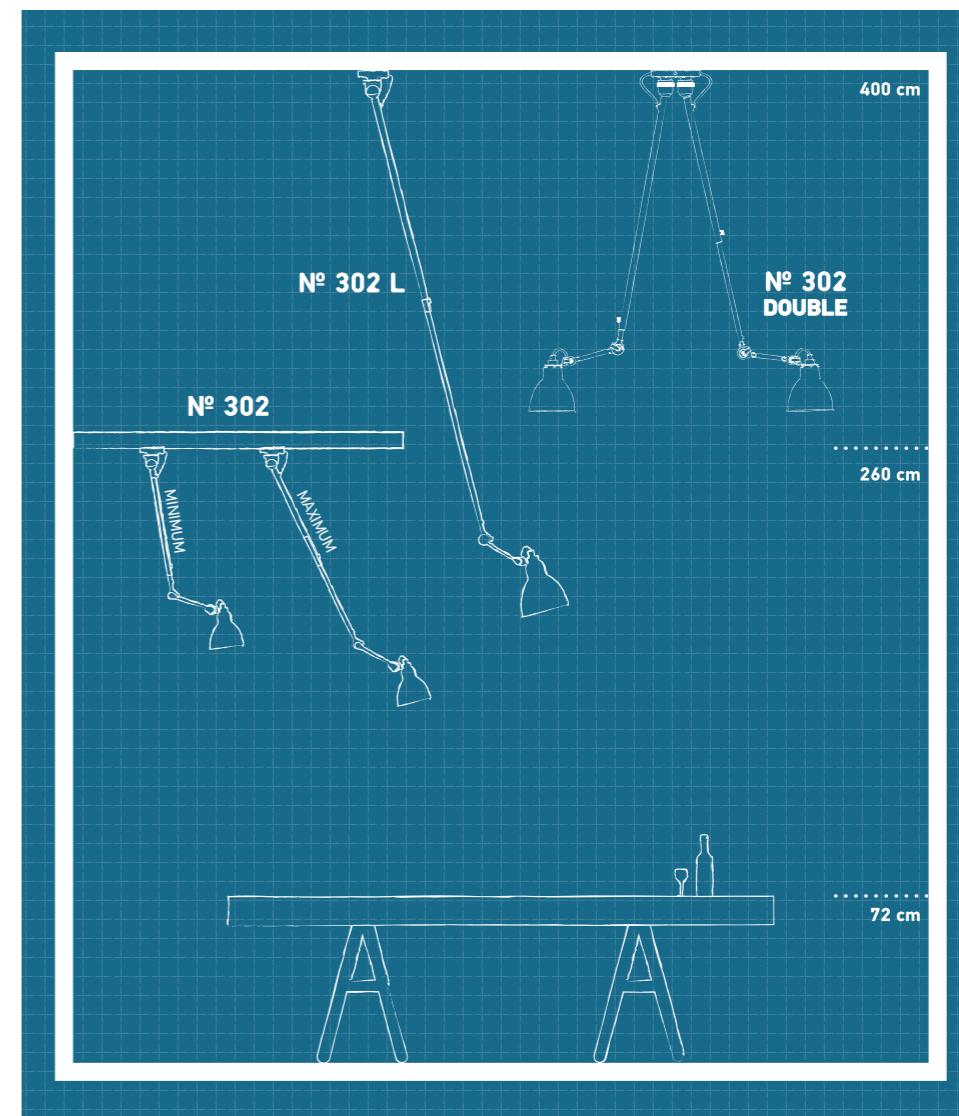





3 x N°302 BL-RED | 2 x N°302 BL-BL

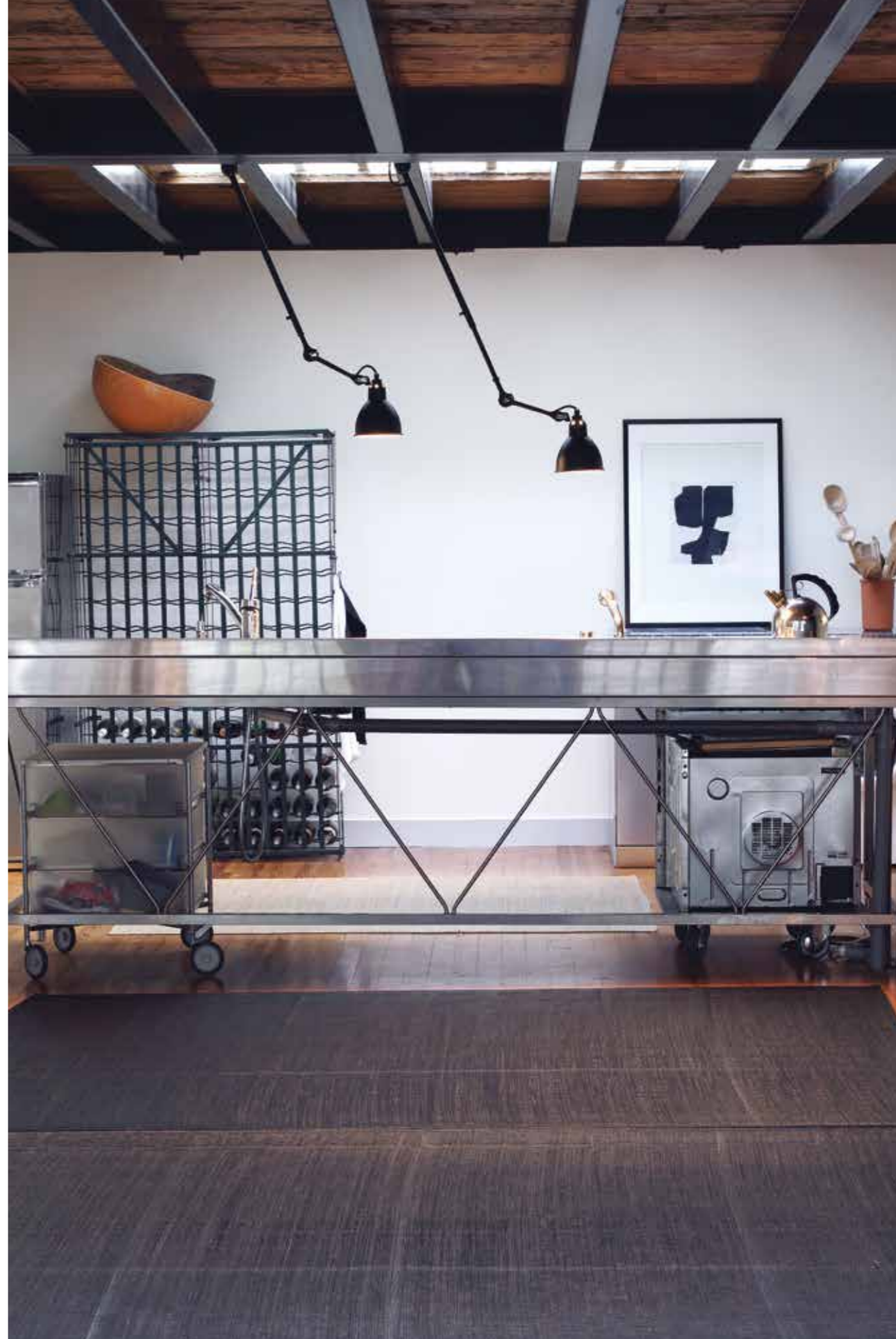





N° 302 L BL-COP-RAW | N° 302 DOUBLE BL-BL



# PLAFONNIERS CEILING LAMPS

## N° 312 N° 312 L

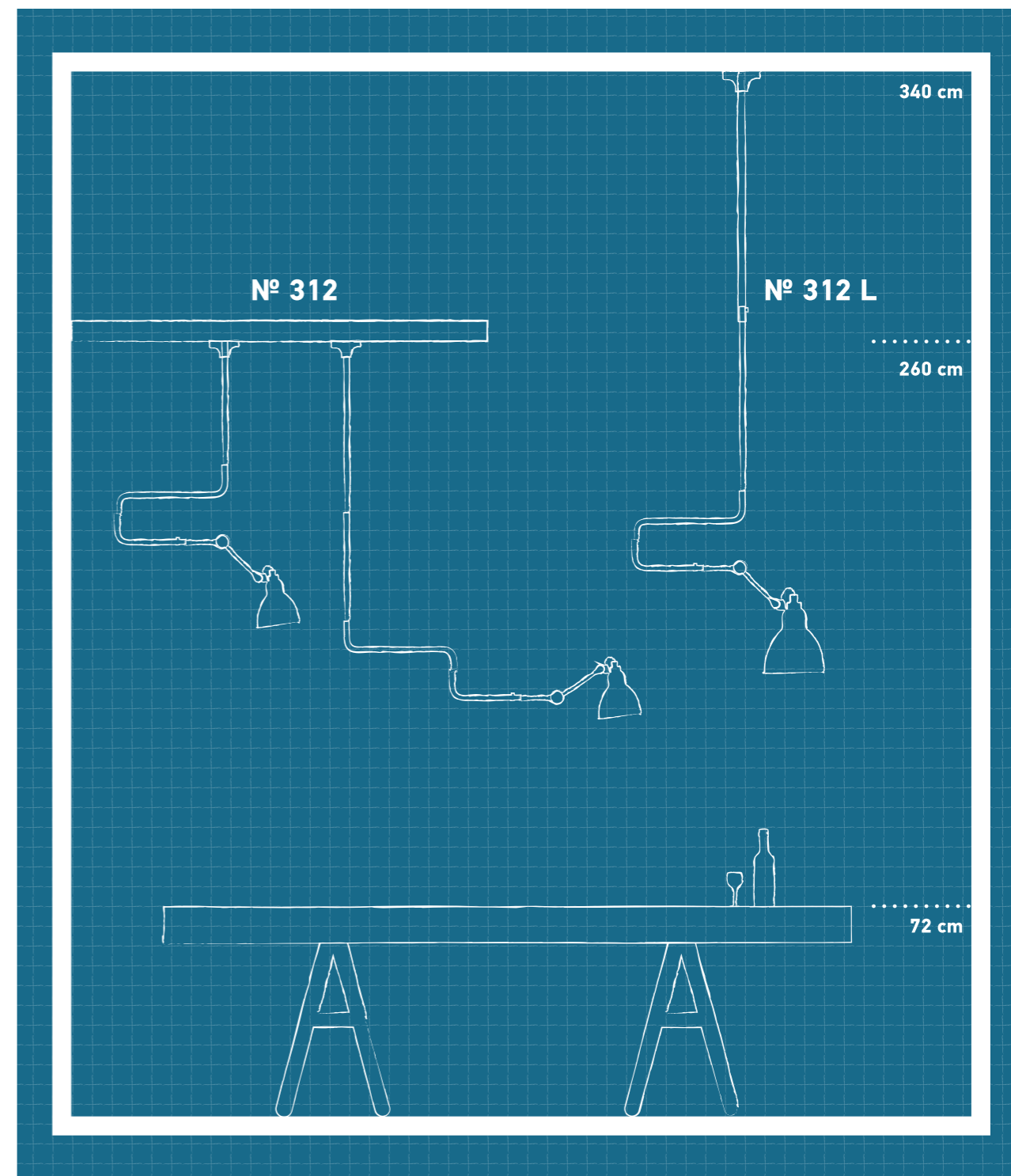



N° 312 BL-COP



3 x N° 312 L BL-BL



LAMPE GRAS  
OUTDOOR SEASIDE



N° 304 XL  
OUTDOOR SEA

**IN THE TUBE (ITT) IP64**  
With or without Mesh

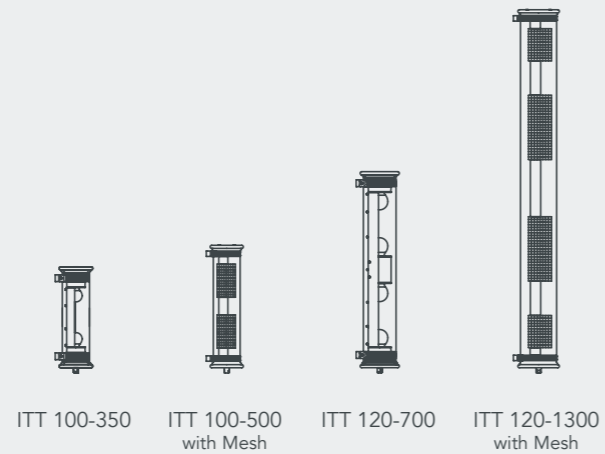

ITT 100-350

ITT 100-500  
with Mesh

ITT 120-700

ITT 120-1300  
with Mesh

**IN THE TUBE 360° (ITT 360°) IP65**

With or without Mesh  
Available in 4 sizes : 400 / 700 / 1000 / 1600  
**FLAP & WING** available in 2 sizes : 1000 & 1600



ITT 360°  
with or without Mesh



ITT 360°  
with Rotating Flap



ITT 360°  
with Mesh  
+ Rotating Flap

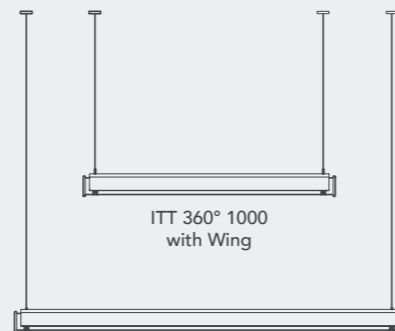

ITT 360° 1000  
with Wing

ITT 360° 1600 with Wing

# COLLECTION OUTDOOR

LA  
LAMPE  
GRAS

# OUT- DOOR SEASIDE

STAINLESS  
STEEL  
316

**Bien fabriquées:**

Les Lampes GRAS OUTDOOR sont conçues pour résister et traverser le temps. Elles sont réalisées avec des matériaux fiables, les fontes sont donc en acier inoxydable, les joints d'étanchéité en silicone, et les réflecteurs sont fermés par des verres en borosilicate.

Nous avons voulu une qualité dans les standards de l'accastillage.

Les Lampes GRAS XL OUTDOOR résistent donc à la pluie, la neige, la salinité, au froid comme au soleil brûlant.



**English • Well made:**

The Lampes GRAS XL OUTDOOR range is designed for durability and weather-resistance, using materials made to resist the elements: stainless steel for the body, silicon for the waterproof seals, borosilicate glass for the reflector casing.

Shipbuilding standards was the level we set ourselves, and the Lampes GRAS XL OUTDOOR are resistant to rain, snow and saltwater as well as to extremes of heat and cold.

**Deutsch • Gut gemacht:**

Die Lampe GRAS XL OUTDOOR ist für einen dauerhaften Einsatz bei widrigen Wetterverhältnissen entwickelt. Widerstandsfähige Materialien werden verwendet. Edelstahl für den Korpus, Silikon für wasserdichte Dichtungen, Borosilikatglas schützt das Reflektorgehäuse.

Wir halten uns an die im Schiffsbau üblichen Normen. Die Lampe GRAS XL OUTDOOR widersteht Regen, Schnee und trotz Salzwasser, aber auch extremer Hitze.



**Italiano • Materiali di pregio:**

La gamma Lampes GRAS XL OUTDOOR è progettata con materiali tali da avere una lunga durata e resistenza agli agenti atmosferici: acciaio inox per il corpo, silicone per le guarnizioni di tenuta, vetro borosilicato per l'involucro del riflettore.

Lo standard della costruzione navale è stato il livello che ci eravamo prefissati, e le Lampes GRAS XL OUTDOOR sono resistenti alla pioggia, alla neve e all'acqua di mare, nonché a caldo e freddo estremi.

**Español • Bien fabricadas:**

Las Lámparas GRAS OUTDOOR y están concebidas para soportar el paso del tiempo. fabricadas con los materiales mas fiables: la estructura en acero inoxidable, juntas de silicona o los reflectores cerrados con vidrios de borosilicato.

Hemos querido utilizar una calidad de construccion naval:

Lámparas GRAS XL In and Out, son por lo tanto resistentes a la lluvia, la nieve, la salinidad o al frío, asi como al sol mas ardiente.





COLLECTION **OUTDOOR**



*Left page*  
N° 304 XL  
OUTDOOR  
BL-BL

*Right page*  
N° 304 XL  
OUTDOOR  
BL-YELLOW





*Left page*  
ITT 120-1300 GOLD-  
GOLD

*Right page*  
ITT 120-1300 GOLD-  
GOLD





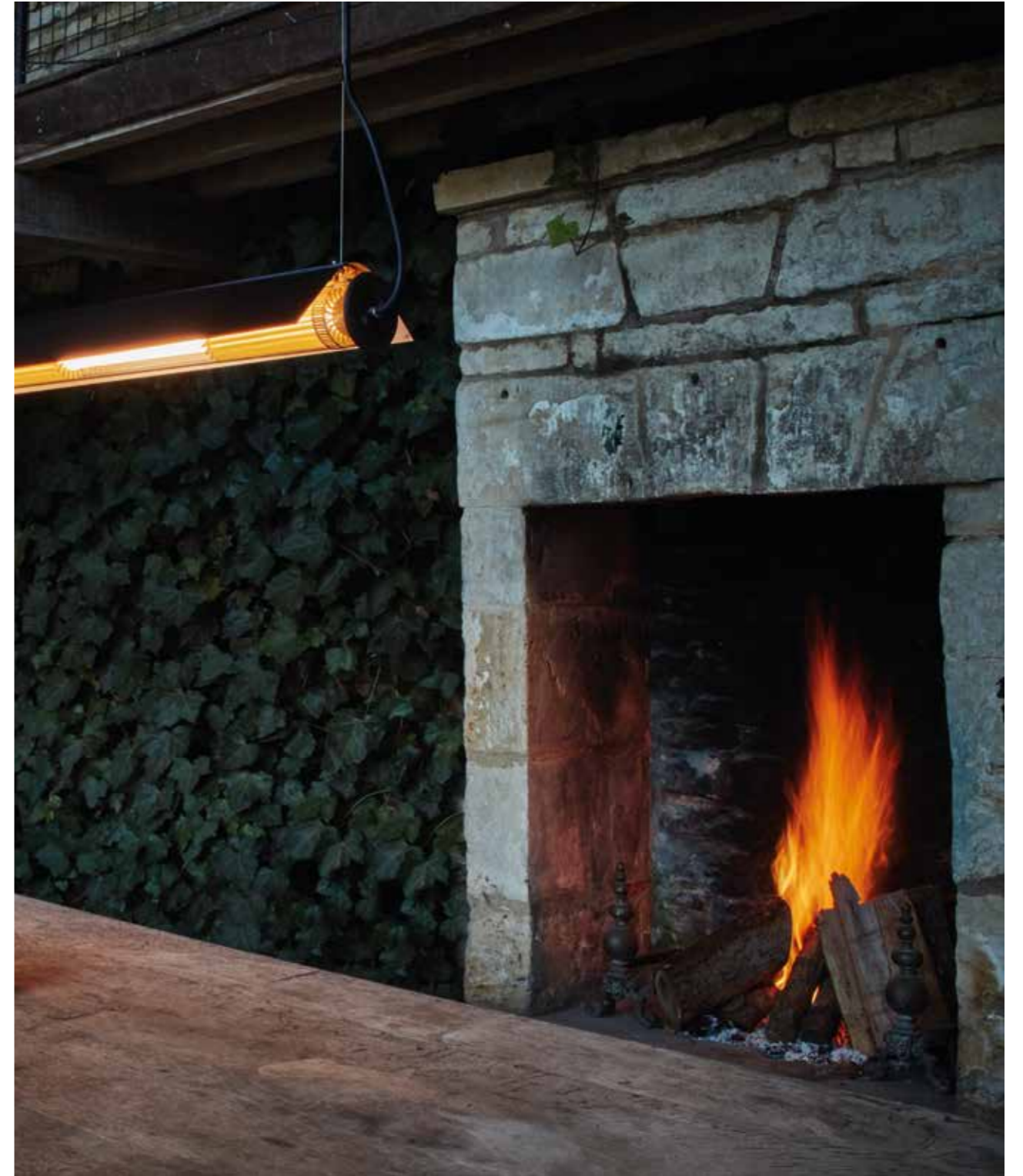

Left and right pages: ITT 360-1600 GOLD (MESH) with black WING





Left page  
ITT 360-1600  
GOLD

Right page  
IITT 120-700  
SILVER-SILVER

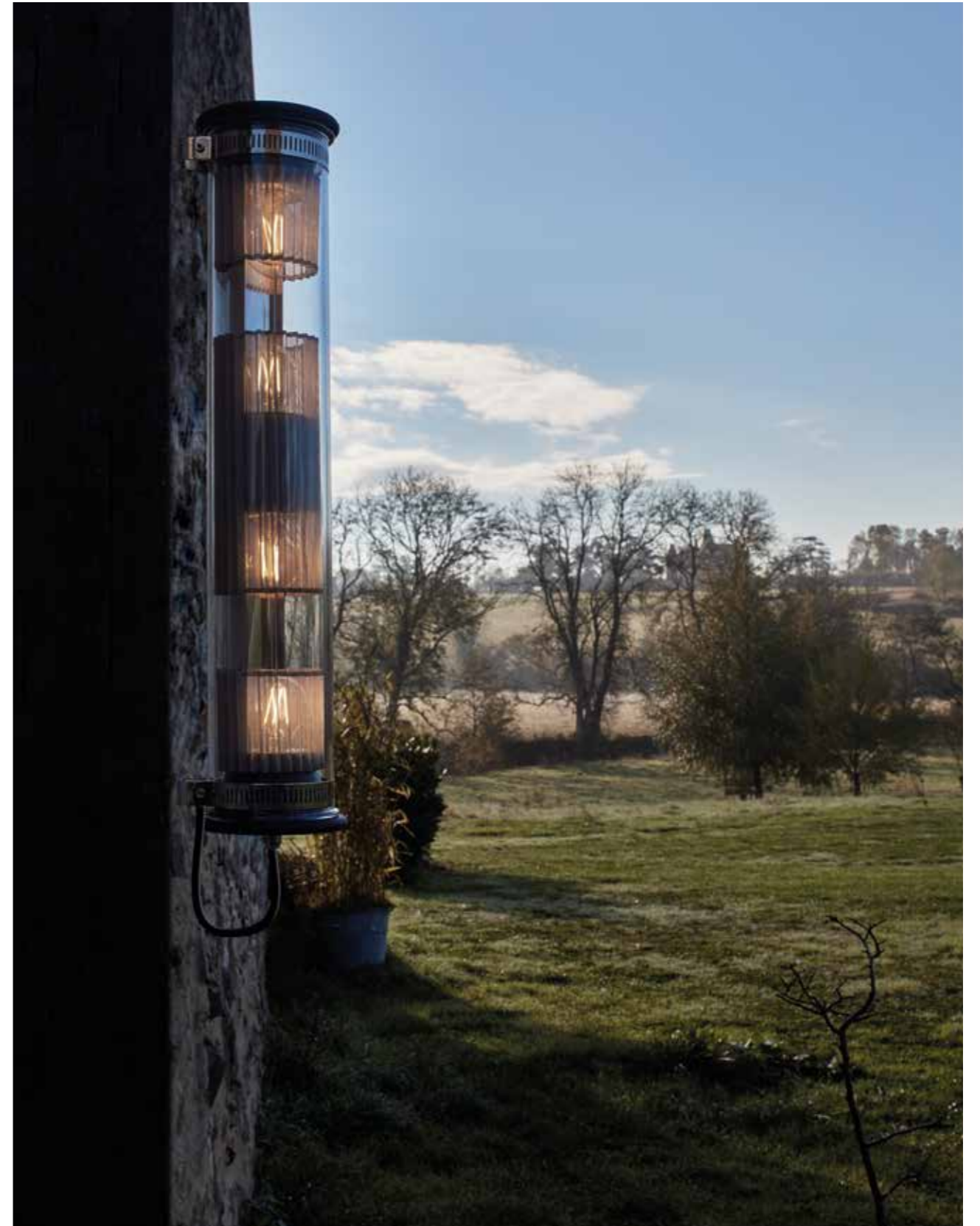



**LAMPE GRAS**  
de Bernard-Albin Gras



N°104  
BATHROOM  
**IP44**



N°304  
BATHROOM  
**IP44**

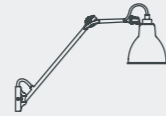

N°122  
BATHROOM  
**IP44**

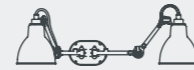

N°204 DOUBLE  
BATHROOM  
**IP44**



**MIROIR**

MY BEST ENEMY MbE  
de DCWéditions

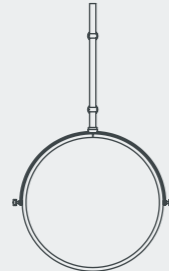
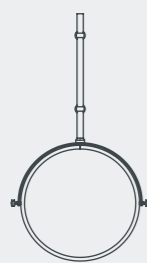

**MIROIR**

TELL ME STORIES TMS  
de Giulia Liverani

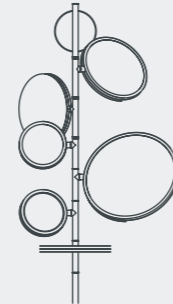

**IN THE TUBE (ITT) IP64 &  
IN THE TUBE 360° (ITT 360°) IP65**  
With or without Mesh

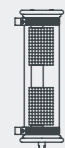

ITT  
100-350



ITT 360°  
400

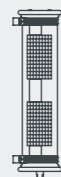

ITT  
100-500



ITT 360°  
700

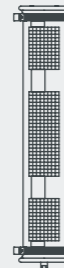

ITT  
120-700



ITT 360°  
1000



ITT  
120-1300



ITT 360°  
1600

# COLLECTION BATHROOM™

# APPLIQUES BATHROOM LAMPS

## N° 304 BATH



### FINISHES

N° 304  
BATHROOM



BLACK



POLYCARBONATE

ABAT JOUR  
DISQUE DE VERRE  
JOINT SILICONE  
CERCLAGE



SHADE  
GLASS DISC  
SILICONE SEAL  
STRAPPING

NEW

## N° 104 BATH



### FINISHES

N° 104  
BATHROOM



BLACK



POLYCARBONATE

ABAT JOUR  
PIÈCE DE MAINTIEN  
GLOBE DE VERRE



SHADE  
HOLDING PART  
GLASS COVER



# APPLIQUES BATHROOM LAMPS

NEW

## N° 122 BATH



### FINISHES

N° 122  
BATHROOM



BLACK



POLYCARBONATE

ABAT JOUR  
PIÈCE DE MAINTIEN  
GLOBE DE VERRE



SHADE  
HOLDING PART  
GLASS COVER

NEW

## N° 204 DOUBLE BATH



### FINISHES

N° 204 DOUBLE  
BATHROOM



BLACK



POLYCARBONATE

ABAT JOUR  
PIÈCE DE MAINTIEN  
GLOBE DE VERRE



SHADE  
HOLDING PART  
GLASS COVER

# LE MIROIR My best Enemy

# LE MIROIR Tell Me Stories

NEW



**MbE**  
BRUSHED NICKEL



**MbE**  
POLISHED BRASS



**MbE**  
POLISHED NICKEL



**MbE**  
BLACK



**TMS**  
BRASS



**TMS**  
BLACK



**TMS**  
NICKEL



# IN THE TUBE

AVEC OU SANS MAILLE  
WITH OR WITHOUT MESH



ITT 100-350  
with MESH



ITT 100-500  
with MESH



ITT 120-700  
with MESH



ITT 120-1300  
with MESH



ITT 360-1600  
with MESH



ITT 360-1000  
with MESH



ITT 360-700  
with MESH



ITT 360-400  
with MESH

IP 64

# IN THE TUBE 360°

AVEC OU SANS MAILLE  
WITH OR WITHOUT MESH

IP 65



NEW

N° 122  
BATHROOM  
BL-PC



NEW

N° 104 BATHROOM BL-PC





Left page  
ITT 120-700 SILVER-SILVER

Right page  
N° 304 BATHROOM BL-PC



*Left page*  
2 x ITT 100-500 GOLD-GOLD  
+ MBE BRUSHED NICKEL

*Right page*  
2 x ITT 360-1000 GOLD





N° 304 BATHROOM BL-PC



ITT 120-700 SILVER-GOLD



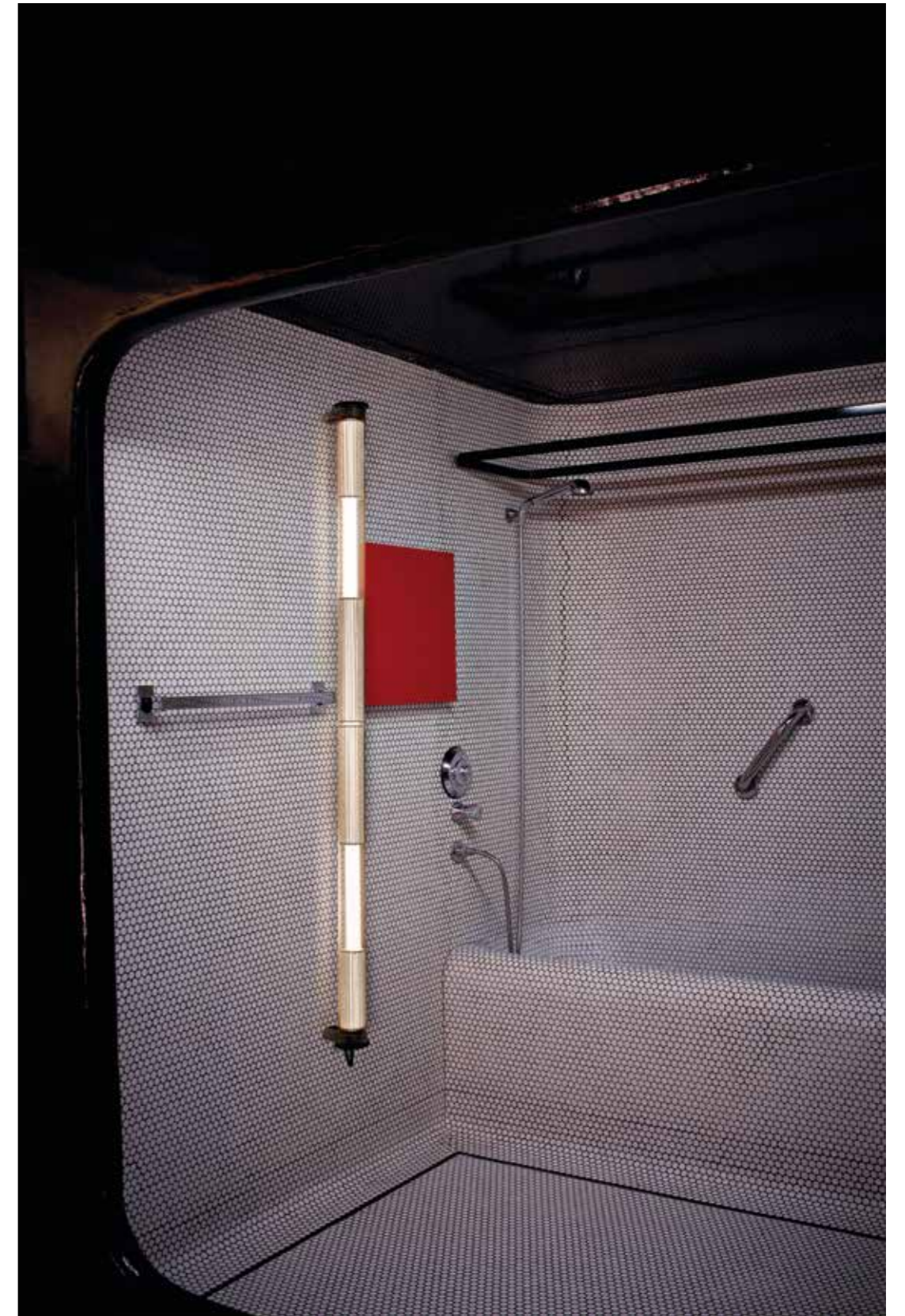

Left page  
N° 304  
BATHROOM  
BL-PC

Right page  
ITT 360-1600  
GOLD (MESH)





*Left page*  
ITT 100-500 GOLD-GOLD

*Right page*  
2 x N° 304 BATHROOM BL-PC  
+ MBE BRUSHED NICKEL





Left page  
TMS BLACK

Right page  
TMS BRASS







Left page  
TMS BLACK

Right page  
TMS NICKEL



# REMERCIEMENTS

Caroline Andréoni Architecte  
Paolo Badesco et Costantino Affuso  
Alberto Bali  
Jean Baptiste Barache  
Sabina Bignami et Alessandro Capellaro de  
l'agence *b-arch, b-arch.it*  
Johan Bouman et Pieter Franssens  
Pascal Breton  
Dominique Brusset  
Carel  
Bertille, Max et Guillaume Chaillet  
Paul Chevillon (Deskopolitan)  
Lucile et Pascale Chombart De Lauwe  
Stéphanie Coudert  
Alix Desforges *espacemaraismarais.com*  
Hélène Devynck  
Regis Dho  
Mark Dillon et Sheila O'Leary  
Ade et Emmanuel Dougier  
Laurence Dougier  
Simon Drotter  
Laurence Du Tilly  
Philippe Garcia et Aude Perrier  
Stéphane Garotin et  
Pierre Emmanuel Martin  
Anne Geistdoefer *doubleg.fr*  
Anne Guiraud et  
Géraldine Perrier-Doron  
Armelle Hédé Haüy  
Veronika Isker  
Laurence Julien et Frédéric Remond  
Virginie Jouve  
Houssam Kanaan et Meghedi Simonian  
(KAAN Design)  
Karine Laski  
Véronique Lecomte  
*veroniquelecomte.fr*  
Jacques Leseur  
Sophie Levitte  
Nicolas Matheus  
Isabelle Mathez  
Arno Mettetal

François Muracciole  
Marie-Pierre Morel  
Paola Navone  
Tsutsuko Nagasawa  
Géraldine Perrier-Doron  
*geraldineperrierdoron.com*  
Isabelle Pierre et Nicolas Fedoroff  
Ema Pradere  
Fredenslip  
Stephanie et Guillaume Reboul  
Pierre et Gwen Ruault  
Shiri et David Slavin  
Dagmar Štěpánová / Formafatal  
Gérard Tracandi  
Sylvie Vaulet  
Patrice Vilaceque  
Yoda de Julip

## Remerciements à

Theika Benevello  
*laqueurie.wordpress.com*  
Château de la Resle  
*chateaudelaresle.com*  
Ludivine et Stephane Degas :  
La Maison Poétique  
*lamaisonpoetique.fr*  
Fondation Marta Pan-Andre Wogenscky  
*pan-wogenscky.com*  
Anne Geistdoerfer  
Veronique Lecomte  
Gabrielle Lindel :  
*lindellandco.com*  
La Folie Douce  
*lafoliedouce.com*  
Le Monde Sauvage :  
*lemondesauvage.com*  
Maisons de vacances :  
*maisondevacances.fr*  
Restaurant Soya  
*soya-cantine-bio.fr*  
Maison Tamboite  
*maisontamboite.fr*

## Remerciements aux artistes

Alberto Bali (p.378)  
Michel Bertrand (p.363)  
George Dupin (p.131, 152, 218  
dont la série Couvent de la Tourette)  
Emmelene Landon (p.141)  
Fondation Marta Pan - André Wogenscky  
*pan-wogenscky.com*  
(p.122- 123, 133, 135, 281, 289)  
Marie-Piere Morel (p.15, 244, 332, 344)  
Bernard Paillard (p.256)  
Géraldine Perrier Doron (p.307)  
*geraldineperrierdoron.com*  
Sabine Pigalle (p261)  
*sabinepigalle.fr*  
Ema Pradere (tableau Yakushima p.267)  
*emapradere.com*  
Thomas King of NAP (p.179)  
Gérard Traquandi (p.265)  
Vincent-Louis Voinchet (p.76, 84)



# CONTACTS

## DCWéditions PARIS

71 rue de la Fontaine au Roi  
75011 Paris – France  
**+33 (0)1 40 21 37 60**

### SHOW ROOM

30-32 rue des 3 Bornes  
75011 Paris – France  
**+33 (0)1 40 21 37 60**

9h à 19h  
Sur rendez-vous  
du lundi au vendredi  
9am to 7pm  
Visit by appointment  
Monday to Friday

### SALES

sales@dcwe.fr  
**+33 1 40 21 37 60**

### FRANCE:

bonjour@dcwe.fr  
**+33 1 40 21 37 60**

### INTERNATIONAL:

international@dcwe.fr  
**+33 1 40 21 37 60**

### CONTRACT:

contract@dcwe.fr  
**+33 1 40 21 19 19**



**dcwe.fr**

### CATALOG

#### Graphisme / Graphic design

Gaëlle Labérine  
gaelle@lagae.fr

Anne Rodeno  
anne.rodeno@gmail.com

#### Photographie / Photography

Ian Scigliuzzi  
www.ianscigliuzzi.com  
ianscigliuzzi@mac.com  
**+33 6 86 34 39 95**

Marie-Pierre Morel (photos et stylisme)  
(p.68, 70, 71, 75, 169, 185, 242, 264, 344)  
www.mariepierremorel.com  
mpm075@gmail.com  
**+33 6 12 08 87 32**

Vincent Leroux  
(p.12-14, 16-17, 22-23, 28-33, 37-41,  
49-53, 61, 76, 78-81, 83-84, 109-111,  
354, 413, 424-427)  
www.vincentleroux.com  
v.leroux@tempsmachine.com  
**+33 6 12 23 97 91**

#### Illustrations Acrobates

Yann Mercier  
yann.mercier@dbmail.com

#### Stylisme / Stylist

Laurence Dougier  
laurencedougier@orange.fr  
@laurencedougier

Ema Pradere  
emapradere.com

Alice Puech

La Lampe GRAS™,  
Les ACROBATES de GRAS™,  
Bernard Schottlander™, MANTIS™,  
IN THE TUBE™, ISP™, BINY™,  
IN THE TUBE 360°™, MbE™,  
HERE COMES THE SUN™,  
IN THE SUN™, BROCHE™, LUNE™,  
SATELLITE™, TRON™, MAP 1™,  
MAP 2™, KNOKKE™, BOUCLE™,  
ORG™, AARO™, RESPIRO™, VVV™,  
FOCUS™, MONO™, ARMEN™,  
LA LAMPE FRECHIN™, YASUKE™,  
MIDNIGHT™, DELUMINA™,  
PAN™, BORELY™, ROSALIE™,  
TOBO™, VISION 20/20™,  
TELL ME STORIES™  
are trademarks of DCW Entreprises

© All rights reserved to DCWéditions  
Printed in January 2022

Cet exemplaire ne peut être vendu  
This catalog can not be sold

**DCW**éditions  
PARIS

71 rue de la Fontaine au Roi  
75011 Paris – France

**SHOW ROOM**

30-32 rue des 3 Bornes  
75011 Paris – France

*9am to 7pm*

*Closed during the week-end*

*Sur rendez-vous / Visit by appointment*

+33 (0)1 40 21 37 60

**dcwe.fr**



**FOCUS** de Yuji Okitsu  
**MONO** de Vantot  
**ARMEN** de Grégoire de Lafforest  
**YASUKE** de BrichetZiegler  
**LA LAMPE FRECHIN** de Jean-Louis Frechin  
**PAN** de Simon Schmitz  
**MIDNIGHT** de Stéphanie Cayet  
**DELUMINA** de Giulia Liverani  
**BORELY** de Eric Gizard  
**ROSALIE** de Julie Fuillet  
**TOBO** de DCWéditions  
**VISION 20/20** de DCWéditions  
**ORG** de Sebastian Summa  
**AARO** de Simon Schmitz  
**VVV** de Vantot  
**RESPIRO** de Philippe Nigro  
**COLLECTION CORDLESS** de Dominique Perrault & Gaëlle Lauriot-Prévost et d'Éric de Dormael  
**BINY** de Jacques Biny  
**IN THE SUN** de Dominique Perrault & Gaëlle Lauriot-Prévost  
**IN THE TUBE** de Dominique Perrault & Gaëlle Lauriot-Prévost  
**ITT 360°** de Dominique Perrault & Gaëlle Lauriot-Prévost  
**COLLECTION** d'Éric de Dormael  
**ISP** de Ilia Sergeevich Potemine  
**MANTIS** de Bernard Schottlander  
**HERE COMES THE SUN** de Bertrand Balas  
**LES ACROBATES DE GRAS**  
**LA LAMPE GRAS** de Bernard-Albin Gras  
**COLLECTION OUTDOOR**  
**COLLECTION BATHROOM**  
**MIROIR MY BEST ENEMY** de DCWéditions  
**MIROIR TELL ME STORIES** de Giulia Liverani